

# Product Specification

- ( ) Product Information
- ( ) Preliminary Specification
- (  ) Approval Specification

*Any modification of Spec is not allowed without SDC's permission.*

CUSTOMER	R/A Customer
DATE OF ISSUE	2018/11/27

MODEL NO.	G490DUE-
EXTENSION CODE	-V(0)

<b>Customer Approval &amp; Feedback</b>

Approved by	
Prepared by	Luo Cianbin

# SPECIFICATION FOR APPROVAL

- Preliminary Specification
- Final Specification

This specification is applicable to 49 "2000cd/m<sup>2</sup>

If there is any change to the specific panel information, we will inform you

## 1. General Description

The IS490DUE is a Color Active Matrix Liquid Crystal Display with an integral Light Emitting Diode (LED) backlight system. The matrix employs a-Si Thin Film Transistor as the active element. It is a transmissive display type which is operating in the normally black mode. It has a 48.50 inch diagonally measured active display area with QWUXGA resolution (1080 vertical by 1920 horizontal pixel array). Each pixel is divided into Red, Green, Blue and White sub-pixels or dots which are arrayed in vertical stripes. Gray scale or the luminance of the sub-pixel color is determined with a 10-bit gray scale signal for each dot. Therefore, it can present a palette of more than 1.07Billion colors.

It has been designed to apply the 10-bit 8 Lane V by One interface.

It is intended to support LCD TV, PCTV where high brightness, super wide viewing angle, high color gamut, high color depth and fast response time are important.

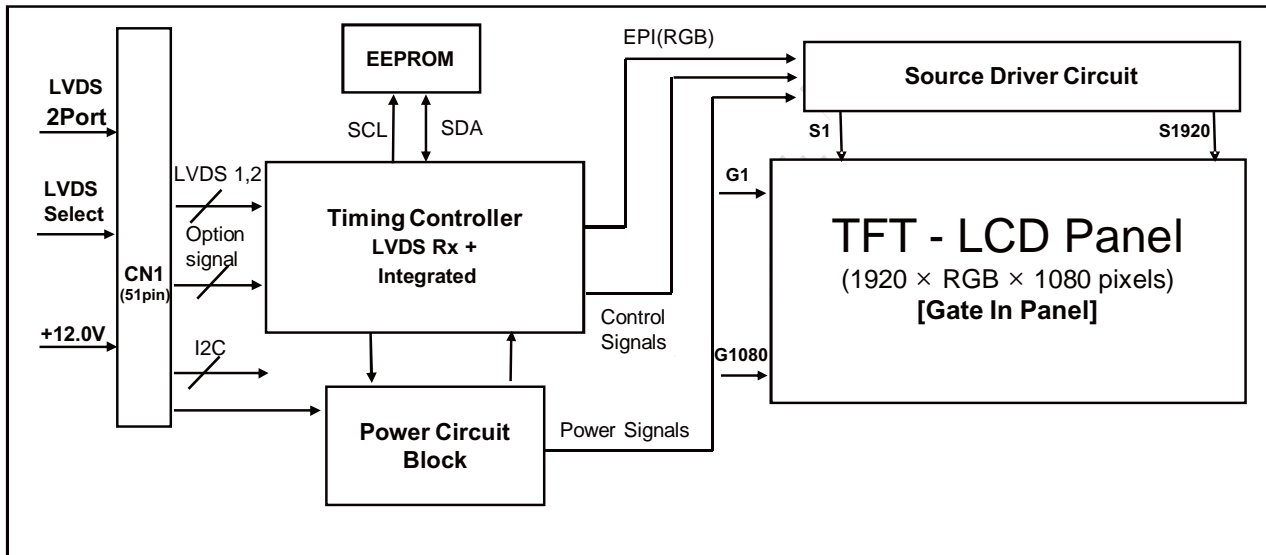

## General Features

Active Screen Size	48.50 inches(1232.00mm) diagonal	
Outline Dimension	1106.4(H) × 641.6(V) × 60.3(D) mm (Typ.)	
Pixel Pitch	0.5593 mm x 0.5593 mm	
Pixel Format	1920 horiz. by 1080 vert.	
Color Depth	8-bit (D), 16.7 M colors	
Luminance, White	2000cd/m <sup>2</sup> (Center 1point ,Typ.)	
Viewing Angle (CR>10)	Viewing angle free ( R/L 178 (Min.), U/D 178 (Min.))	
Power Consumption	2000cd/m <sup>2</sup> Total 171.6W (Typ.)	Includes panel power consumption of 14 W
Weight	14.28kg(Typ.) 15kg(Max)	
Display Mode	Transmissive mode, Normally black	
Surface Treatment	Hard coating(3H), Anti-glare treatment of the front polarizer (Haze 3% Typ.)	

## 2. Absolute Maximum Ratings

The following items are maximum values which, if exceeded, may cause faulty operation or permanent damage to the LCD module.

**Table 1. ABSOLUTE MAXIMUM RATINGS**

Parameter		Symbol	Value		Unit	Note
			Min	Max		
Power Input Voltage	LCD Circuit	V <sub>LCD</sub>	-0.3	+14.0	V <sub>DC</sub>	1
T-Con Option Selection Voltage		V <sub>LOGIC</sub>	-0.3	+4.0	V <sub>DC</sub>	
Operating Temperature		T <sub>OP</sub>	0	+50	°C	2
Storage Temperature (without packing)		T <sub>ST</sub>	-20	+60	°C	
Panel Front Temperature		T <sub>SUR</sub>	-	+68	°C	3
Operating Ambient Humidity		H <sub>OP</sub>	10	90	%RH	2
Storage Humidity		H <sub>ST</sub>	5	90	%RH	

Note1. Ambient temperature condition ( $T_a = 25 \pm 2 \text{ }^\circ\text{C}$ )

2. Temperature and relative humidity range are shown in the figure below.

Wet bulb temperature should be Max 39°C, and no condensation of water.

3. The maximum operating temperatures is based on the test condition that the surface temperature of display area is less than or equal to 68°C with LCD module alone in a temperature controlled chamber. Thermal management should be considered in final product design to prevent the surface temperature of display area from being over 68°C. The range of operating temperature may be degraded in case of improper thermal management in final product design.

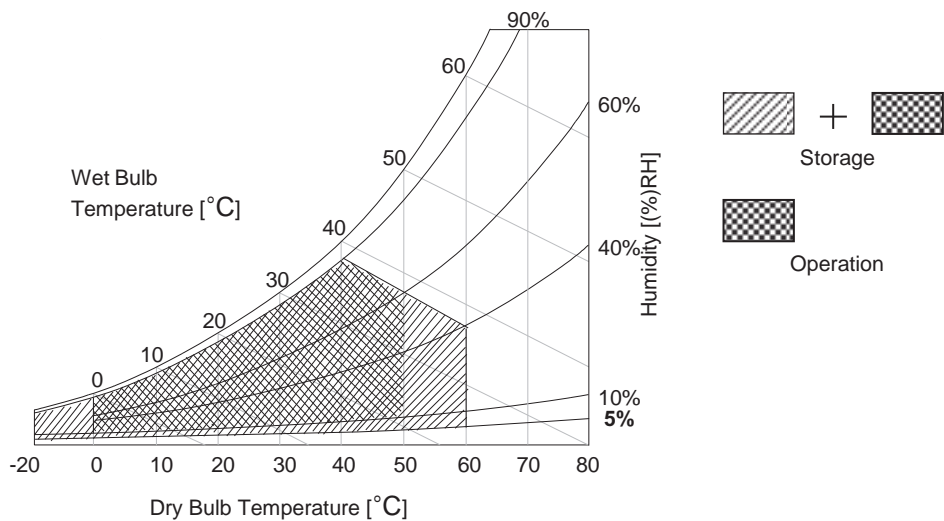

### 3. Electrical Specifications

#### 3-1. Electrical Characteristics

It requires several power inputs. The VCC is the basic power of LCD Driving power sequence, Which is used to logic power voltage of Source D-IC and GIP.

Table 2. ELECTRICAL CHARACTERISTICS

Parameter	Symbol	Value			Unit	Note	
		Min	Typ	Max			
<b>Circuit :</b>							
Power Input Voltage	V <sub>LCD</sub>	10.8	12	13.2	V <sub>DC</sub>		
Power Input Current	I <sub>LCD</sub>	-	1370	1780	mA	1	
		-	1900	2470	mA	2	
T-CON Option Selection Voltage	Input High Voltage	V <sub>IH</sub>	2.7	-	3.6	V <sub>DC</sub>	
	Input Low Voltage	V <sub>IL</sub>	0	-	0.7	V <sub>DC</sub>	
Power Consumption	P <sub>LCD</sub>	-	16.4	21.4	Watt	1	
Rush current	I <sub>RUSH</sub>	-	-	10	A	3	

- Notes
1. The specified current and power consumption are under the V<sub>LCD</sub>=12.0V, Ta=25 ± 2°C, f<sub>v</sub>=60Hz condition, and mosaic pattern(8 x 6) is displayed and f<sub>v</sub> is the frame frequency.
  2. The current is specified at the maximum current pattern.
  3. The duration of rush current is about 2ms and rising time of power input is 0.5ms (min.).
  4. Ripple voltage level is recommended under ±5% of typical voltage

White : 255 Gray  
 Black : 0 Gray

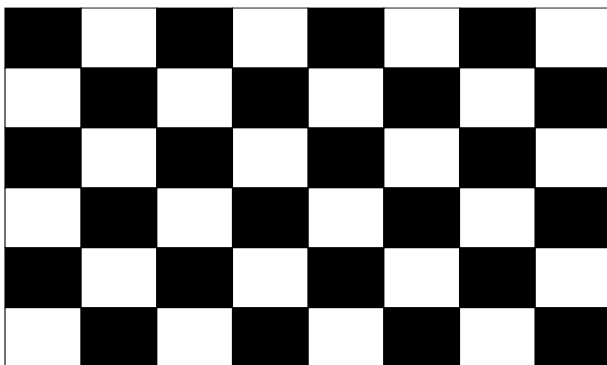

Mosaic Pattern(8 x 6)

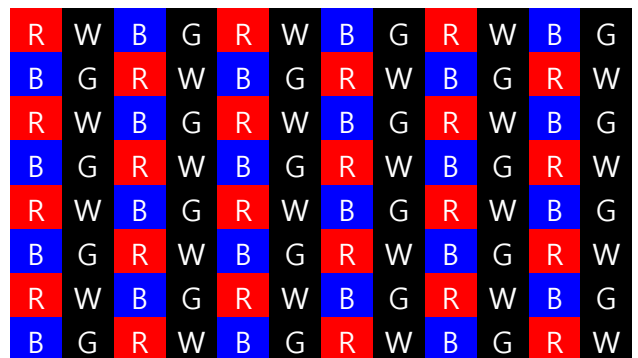

Max current pattern ( Full magenta )

### 3-2. Interface Connections

This LCD module employs two kinds of interface connection, 51-pin connector is used for the module electronics.

#### 3-2-1. LCD Module

- LCD Connector(CN1): 05030HR-H51H (manufactured by YEONHO) or compatible

**Table 3. MODULE CONNECTOR (CN1) PIN CONFIGURATION**

No	Symbol	Description	No	Symbol	Description
1	VLCD	Power Supply +12.0V	27	GND	Ground
2	VLCD	Power Supply +12.0V	28	Rx0n	V-by-One HS Data Lane 0
3	VLCD	Power Supply +12.0V	29	Rx0p	V-by-One HS Data Lane 0
4	VLCD	Power Supply +12.0V	30	GND	Ground
5	VLCD	Power Supply +12.0V	31	Rx1n	V-by-One HS Data Lane 1
6	VLCD	Power Supply +12.0V	32	Rx1p	V-by-One HS Data Lane 1
7	VLCD	Power Supply +12.0V	33	GND	Ground
8	VLCD	Power Supply +12.0V	34	Rx2n	V-by-One HS Data Lane 2
9	NC	NO CONNECTION	35	Rx2p	V-by-One HS Data Lane 2
10	GND	Ground	36	GND	Ground
11	GND	Ground	37	Rx3n	V-by-One HS Data Lane 3
12	GND	Ground	38	Rx3p	V-by-One HS Data Lane 3
13	GND	Ground	39	GND	Ground
14	PWM TIN	External VBR (From System)	40	Rx4n	V-by-One HS Data Lane 4
15	PWM TOUT	External VBR (For System)	41	Rx4p	V-by-One HS Data Lane 4
16	Mplus Mode 0	Input Data Format [1:0] '00':Low Power, '01':High Luminance '10':High Luminance II, '11':PC Mode	42	GND	Ground
17	Mplus Mode 1		43	Rx5n	V-by-One HS Data Lane 5
18	SDA	SDA (For I2C)	44	Rx5p	V-by-One HS Data Lane 5
19	SCL	SCL (For I2C)	45	GND	Ground
20	NC	NO CONNECTION	46	Rx6n	V-by-One HS Data Lane 6
21	NC	NO CONNECTION	47	Rx6p	V-by-One HS Data Lane 6
22	Data format	'L' or NC:Non division, 'H':2 division	48	GND	Ground
23	AGP or NSB	'H' : AGP, 'L' or NC: : NSB	49	Rx7n	V-by-One HS Data Lane 7
24	NC	NO CONNECTION	50	Rx7p	V-by-One HS Data Lane 7
25	HTPDN	Hot plug detect	51	GND	Ground
26	LOCKN	Lock detect	-	-	-

3-2-2. Backlight Module

parameter	Symbol	VALUES			Unit	Notes
		MIN	TYP	MAX		
Power supply input voltage	VBL	23	24	25	VDC	1
Power supply input current	IBL_A		5.3		A	1500
Power consumption	PBL		207		W	cd/m <sup>2</sup>
Power supply input current	IBL_A		6		A	2000
Power consumption	PBL		264		W	cd/m <sup>2</sup>
Power supply input current	IBL_A		6.9		A	2500
Power consumption	PBL		319		W	cd/m <sup>2</sup>
Power supply input current	IBL_A		7.7		A	3000
Power consumption	PBL		378		W	cd/m <sup>2</sup>
Input signal for inverter control	on	V on	2.5		5	V
	off	V off	0		0.5	V
Brightness adjust	EXTVBR-B	30		100	%	Automatic sensitization control

Rear view of LCM

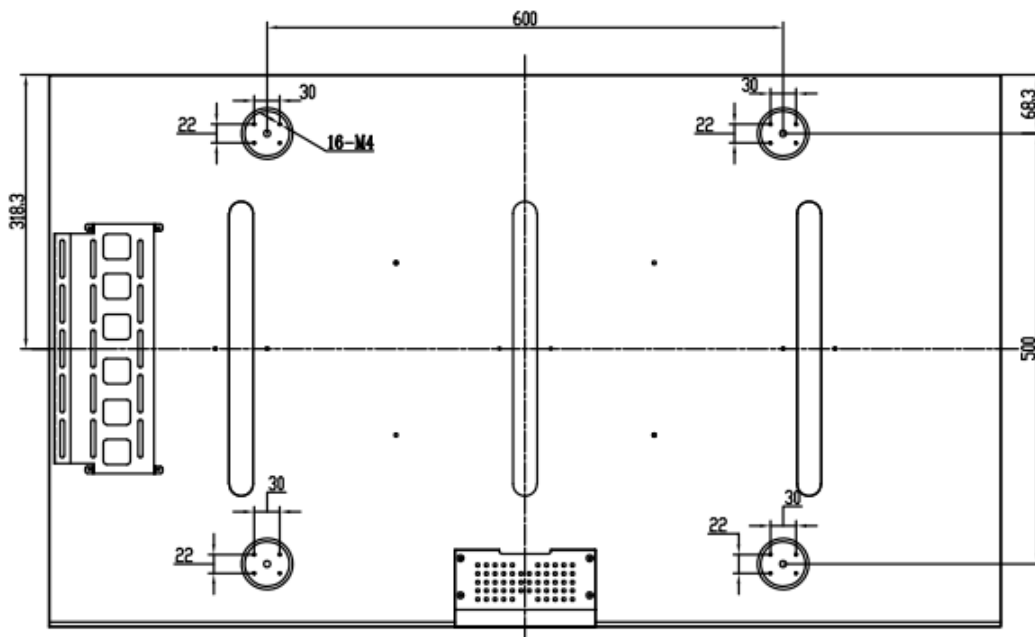

Note: Any one can be selected as the main control board

## Product Specification

### 2、LED constant current board interface (LED 恒流板接口)

#### 2.1 Board A ( Designated master control board )

P001 PH2.0-14PIN (2.0mm\*14)      P002 PH2.0-2PIN (2.0mm\*2)

Pin NO.	symbol	P001 Description	P002 Description	note
1	VCC	Power Supply Voltage	Light sensor negative pole -	
2	VCC	Power Supply Voltage	Light sensor positive pole +	
3	VCC	Power Supply Voltage		
4	VCC	Power Supply Voltage		
5	VCC	Power Supply Voltage		
6	GND	Power ground		
7	GND	Power ground		
8	GND	Power ground		
9	GND	Power ground		
10	GND	Power ground		
11	NC	Not connect		
12	ON/OFF	Output enable signal		
13	NC	Not connect		
14	NC	Not connect		

#### 2.2 Board B ( Constant current plate except main control plate )

P001 PH2.0-14PIN (2.0mm\*14)      P002 PH2.0-2PIN (2.0mm\*2)

Pin NO.	symbol	P001 Description	P002 Description	note
1	VCC	Power Supply Voltage	NC	
2	VCC	Power Supply Voltage	NC	
3	VCC	Power Supply Voltage		
4	VCC	Power Supply Voltage		
5	VCC	Power Supply Voltage		
6	GND	Power ground		
7	GND	Power ground		
8	GND	Power ground		
9	GND	Power ground		
10	GND	Power ground		
11	NC	Not connect		
12	NC	Not connect		
13	NC	Not connect		
14	NC	Not connect		



### 3-3. Signal Timing Specifications

Table 6 shows the signal timing required at the input of the Vx1 transmitter. All of the interface signal timings should be satisfied with the following specification for normal operation.

**Table 6. TIMING TABLE (DE Only Mode)**

ITEM		Symbol	Min	Typ	Max	Unit	Note
Horizontal	Display Period	$t_{HV}$	480	480	480	$t_{CLK}$	3840/8
	Blank	$t_{HB}$	60	70	120	$t_{CLK}$	1
	Total	$t_{HP}$	540	550	600	$t_{CLK}$	
Vertical	Display Period	$t_{VV}$	2160	2160	2160	Lines	
	Blank	$t_{VB}$	40	90	600	Lines	1
	Total	$t_{VP}$	2200	2250	2760	Lines	

ITEM		Symbol	Min	Typ	Max	Unit	Note
Frequency	DCLK	$f_{CLK}$	60	74.25	78.00	MHz	594/8
	Horizontal	$f_H$	121.8	135	140	KHz	2
	Vertical	$f_V$	47	60	63	Hz	2

notes: 1. The input of HSYNC & VSYNC signal does not have an effect on normal operation (DE Only Mode).  
If you use spread spectrum of EMI, add some additional clock to minimum value for clock margin.

2. The performance of the electro-optical characteristics may be influenced by variance of the vertical refresh rate and the horizontal frequency

3. Spread Spectrum Rate (SSR) is limited to  $\pm 0.5\%$  center spread at 30KHz

※ Timing should be set based on clock frequency.

3-4. V by One input signal Characteristics

3-4-1. V by One Input Signal Timing Diagram

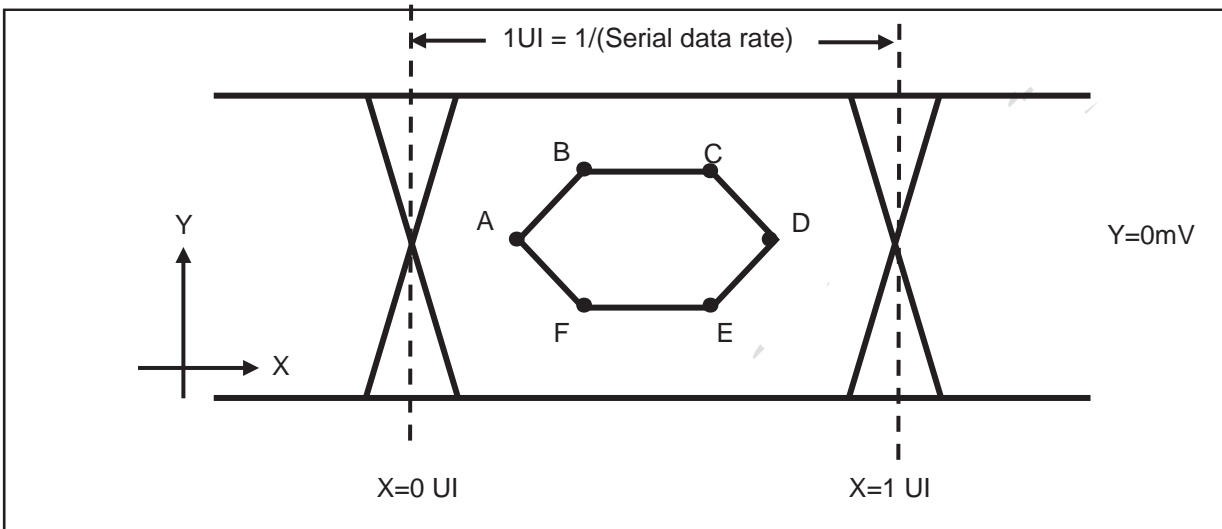
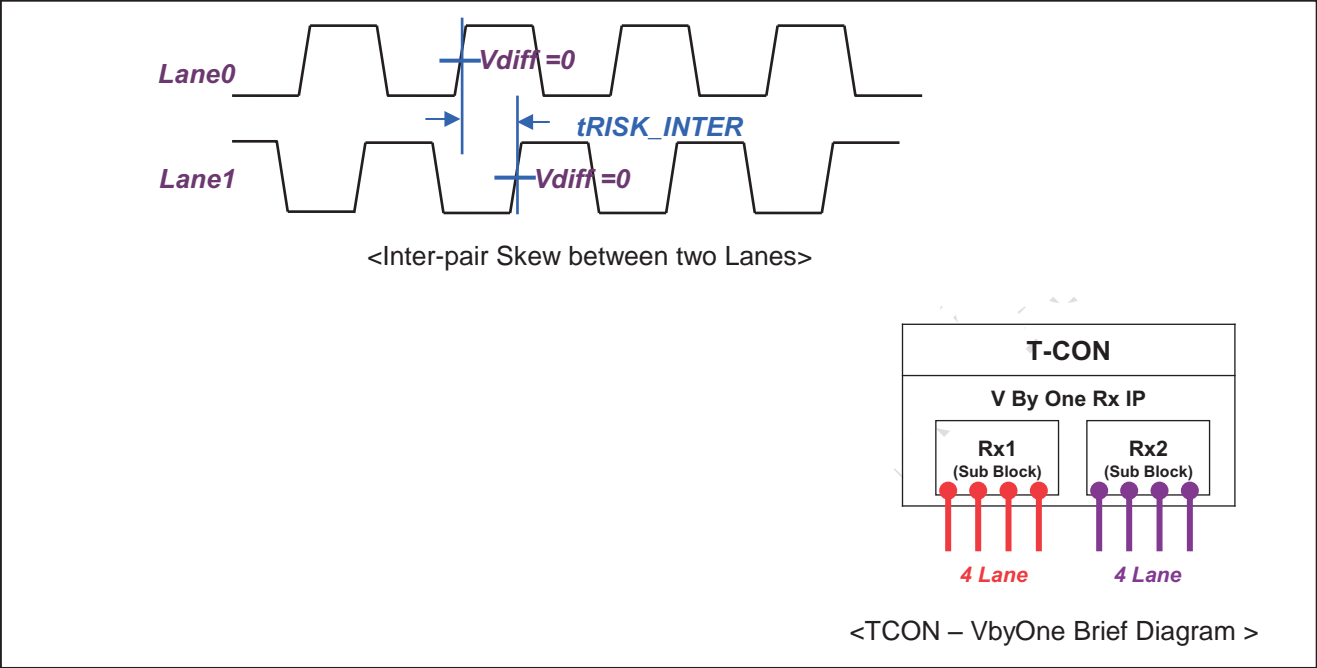

Table7. Eye Mask Specification

	X[UI]	Note	Y[mV]	Note
A	0.25 (max)	2	0	-
B	0.3 (max)	2	50	3
C	0.7(min)	3	50	3
D	0.75(min)	3	0	-
E	0.7(min)	3	-50	3
F	0.3(max)	2	-50	3

- notes
1. All Input levels of V by One signals are based on the V by One HS Standard Ver. 1.4
  2. This is allowable maximum value.
  3. This is allowable minimum value.
  4. The eye diagram is measured by the oscilloscope and receiver CDR characteristic must be emulated.
    - PLL bandwidth : 15 Mhz
    - Damping Factor : 1.5

3-4-2. V by One Input Signal Characteristics



Description	Symbol	Min	Max	Unit	notes
Allowable inter-pair skew between lanes	$t_{RISK\_INTER}$	-	5	UI	1,2

- Notes 1.  $1UI = 1/\text{serial data rate}$
- 2. it is the time difference of the differential voltage between any two lanes .

### 3-5. Intra interface Signal Specification

#### 3-5-1. EPI Signal Specification

Table 8. ELECTRICAL CHARACTERISTICS

Parameter	Symbol	Condition	MIN	TYP	MAX	Unit	notes
Logic & EPI Power Voltage	VCC	-	1.79	1.88	1.98	VDC	
EPI input common voltage	VCM	CML Type	0.8	-	1.2-Vdiff/2	V	
EPI input differential voltage	Vdiff	-	150	-	500	mV	
EPI Input eye diagram	Veye	-	90	-	-	mV	
Effective Veye width time	B1&B2	-	0.25	-	-	UI	

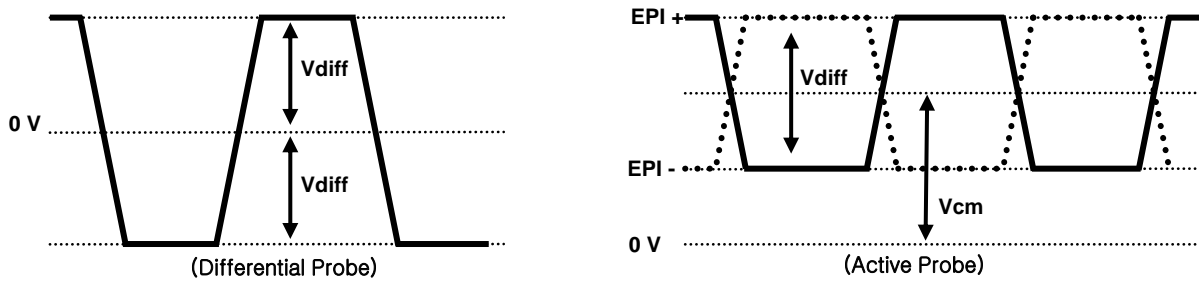

EPI Differential signal characteristics

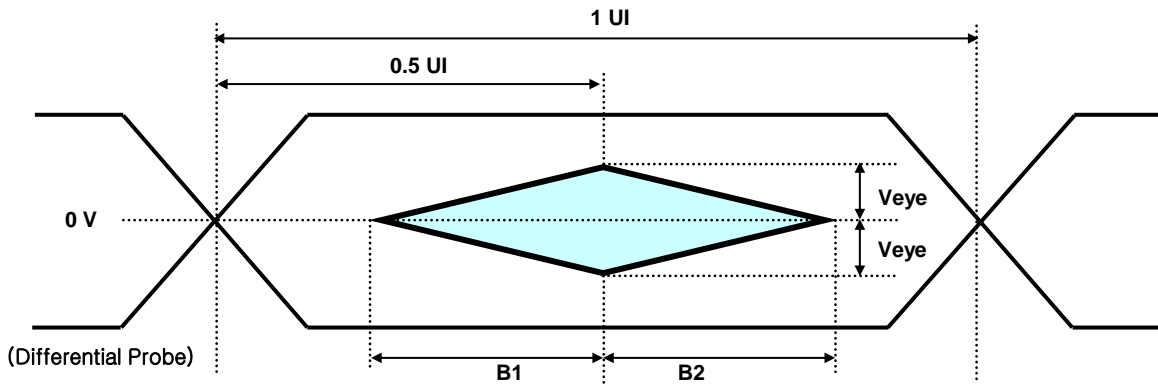

Eye Pattern of EPI Input

\*Source PCB

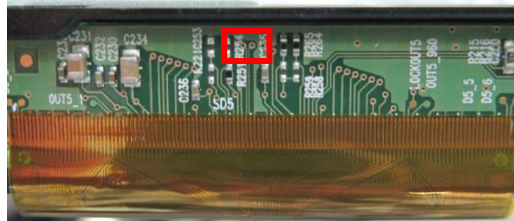

FIG. 3 Measure point

### 3-5-2. Color Data Reference

The brightness of each primary color (red, green, blue) is based on the 10bit gray scale data input for the color. The higher binary input, the brighter the color. Table 7 provides a reference for color versus data input.

Packer input & Unpacker output		30bpp RGB (10bit)
Byte0	D[0]	R[2]
	D[1]	R[3]
	D[2]	R[4]
	D[3]	R[5]
	D[4]	R[6]
	D[5]	R[7]
	D[6]	R[8]
	D[7]	R[9]
Byte1	D[8]	G[2]
	D[9]	G[3]
	D[10]	G[4]
	D[11]	G[5]
	D[12]	G[6]
	D[13]	G[7]
	D[14]	G[8]
	D[15]	G[9]
Byte2	D[16]	B[2]
	D[17]	B[3]
	D[18]	B[4]
	D[19]	B[5]
	D[20]	B[6]
	D[21]	B[7]
	D[22]	B[8]
	D[23]	B[9]
Byte3	D[24]	Don't care
	D[25]	Don't care
	D[26]	B[0]
	D[27]	B[1]
	D[28]	G[0]
	D[29]	G[1]
	D[30]	R[0]
	D[31]	R[1]

### 3-6. Power Sequence

#### 3-6-1. LCD Driving circuit

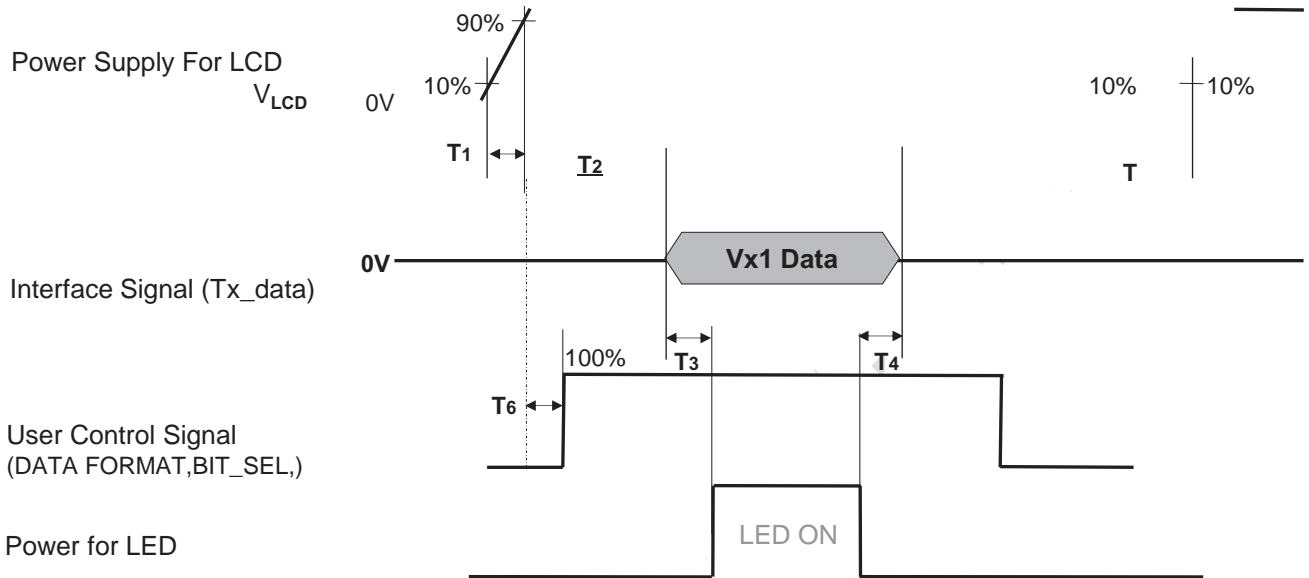

Table 9. POWER SEQUENCE

Parameter	Value			Unit	Notes
	Min	Typ	Max		
T1	0.5	-	20	ms	1
T2	0	-	-	ms	2
T3	400	-	-	ms	3
T4	100	-	-	ms	3
T5	1.0	-	-	s	4
T6	0	-	T2	ms	5
T7	0	-	-	ms	6

- Note :
1. Even though T1 is over the specified value, there is no problem if I2T spec of fuse is satisfied.
  2. If T2 is satisfied with specification after removing LVDS Cable, there is no problem.
  3. The T3 / T4 is recommended value, the case when failed to meet a minimum specification, abnormal display would be shown. There is no reliability problem.
  4. T5 should be measured after the Module has been fully discharged between power off and on period.
  5. If the on time of signals (Interface signal and user control signals) precedes the on time of Power ( $V_{LCD}$ ), it will be happened abnormal display. When T6 is NC status, T6 doesn't need to be measured.
  6. It is recommendation specification that T7 has to be 0ms as a minimum value.
- ※ Please avoid floating state of interface signal at invalid period.
  - ※ When the power supply for LCD ( $V_{LCD}$ ) is off, be sure to pull down the valid and invalid data to 0V.

### 4. Optical Specification

Optical characteristics are determined after the unit has been 'ON' and stable in a dark environment at  $25 \pm 2^\circ\text{C}$ . The values are specified at distance 50cm from the LCD surface at a viewing angle of  $\Phi$  and  $\theta$  equal to  $0^\circ$ . FIG. 1 shows additional information concerning the measurement equipment and method.

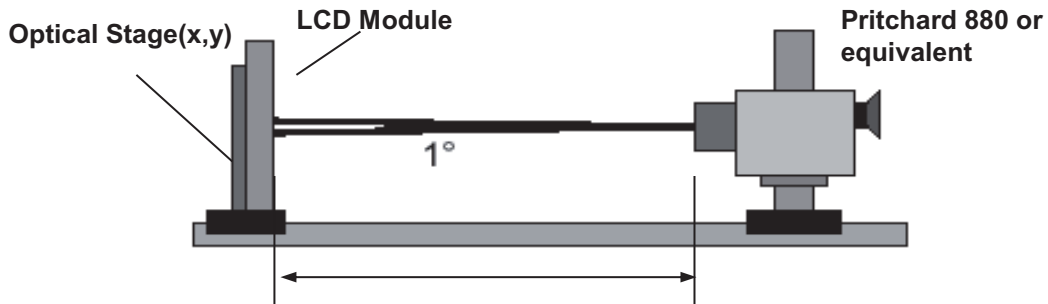

$T_a = 25 \pm 2^\circ\text{C}$ ,  $V_{LCD} = 12.0\text{V}$ ,  $f_v = 60\text{Hz}$ ,  $D_{clk} = 74.25\text{MHz}$   
 Light Source : D65 Standard

Table 11. OPTICAL CHARACTERISTICS

Parameter	Symbol	Value			Unit	Note	
		Min	Typ	Max			
Contrast Ratio	CR	900	1300	-		1	
Response Time	Variation	G to G <sub>σ</sub>	6	9		3	
	Gray to Gray (BW)	G to G <sub>BW</sub>	9	13	ms	2	
	T	7.38	8.20		%	4	
Color Coordinates [CIE1931]	RED	Rx		0.665		5	
		Ry		0.323			
	GREEN	Gx	Typ	0.276	Typ		
		Gy	-0.03	0.597	+0.03		
	BLUE	Bx		0.134			
		By		0.118			
Viewing Angle (CR>10)							
	x axis, right ( $\phi=0^\circ$ )	$\theta_r$	89	-	-	degree	6
	x axis, left ( $\phi=180^\circ$ )	$\theta_l$	89	-	-		
	y axis, up ( $\phi=90^\circ$ )	$\theta_u$	89	-	-		
	y axis, down ( $\phi=270^\circ$ )	$\theta_d$	89	-	-		
Gray Scale			-	-	-		7

## Product Specification

notes :1. Contrast Ratio(CR) is defined mathematically as :

CR(Contrast Ratio) = Maximum CR<sub>n</sub> (n=1, 2, 3, 4, 5)  
 Surface Luminance at position n with all white pixels

CR<sub>n</sub> =  $\frac{\text{Surface Luminance at position n with all white pixels}}{\text{Surface Luminance at position n with all black pixels}}$

n = the Position number(1, 2, 3, 4, 5). For more information, see FIG 2.

The value of CR should be extracted using the LGD sheet structure (Diffuser/Prism/Prism)

2. Response time is the time required for the display to transit from any gray to white (Rise Time, TrR) and from any gray to black (Decay time, TrD). For additional information see the FIG. 3.

※ G to GBW Spec stands for average value of all measured points.

Photo Detector : RD-80S / Field : 2 °

The response time is valued with operating condition of LGD's standard BLU

3. G to G σ is Variation of Gray to Gray response time composing a picture

G to G (σ) =

$$\sqrt{\frac{\sum(X_i - u)^2}{N}}$$

X<sub>i</sub> = Individual Data

u = Data average

N : The number of Data

4. The value of transmittance should be extracted using the standard light source of D65

5. The value of color coordinates should be extracted using the standard light source of D65

6. Viewing angle is the angle at which the contrast ratio is greater than 10. The angles are determined for the horizontal or x axis and the vertical or y axis with respect to the z axis which is normal to the LCD module surface. For more information, see the FIG. 4.

7. Gray scale specification

Gamma Value is approximately 2.2. For more information, see the Table 10.

**Table 12. GRAY SCALE SPECIFICATION**

Gray Level	Luminance [%] (Typ)
L0	0.077
L63	0.27
L127	1.04
L191	2.49
L255	4.68
L319	7.66
L383	11.5
L447	16.1
L511	21.6
L575	28.1
L639	35.4
L703	43.7
L767	53.0
L831	63.2
L895	74.5
L959	86.7
L1023	100



Measuring point for surface luminance & measuring point for luminance variation.

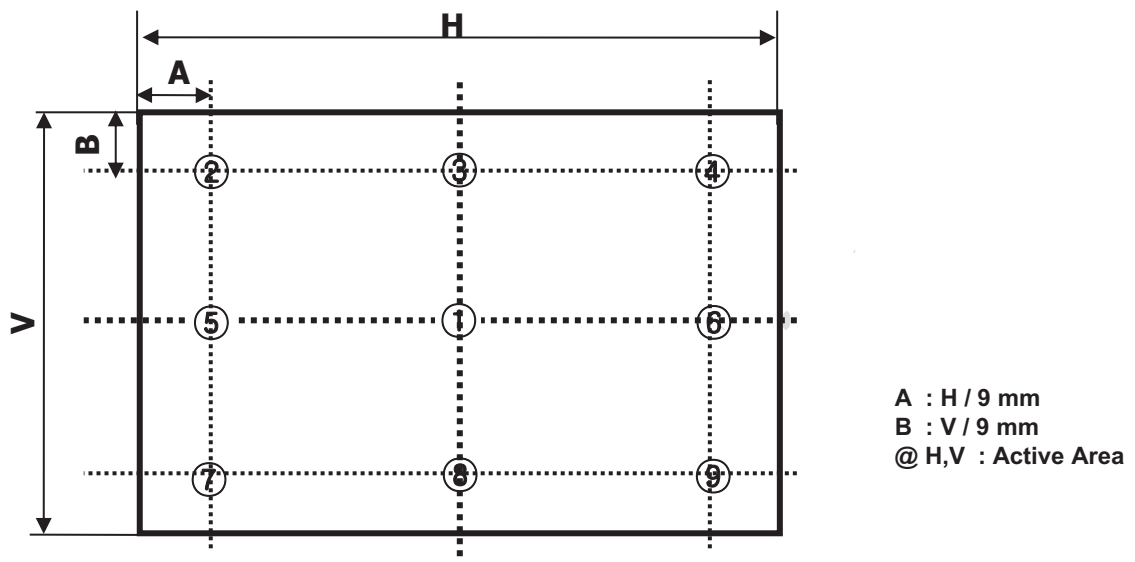

Response time is defined as the following figure and shall be measured by switching the input signal for "Gray(0)" ~ "Gray(255)" and "Gray(255)" ~ "Gray(0)".

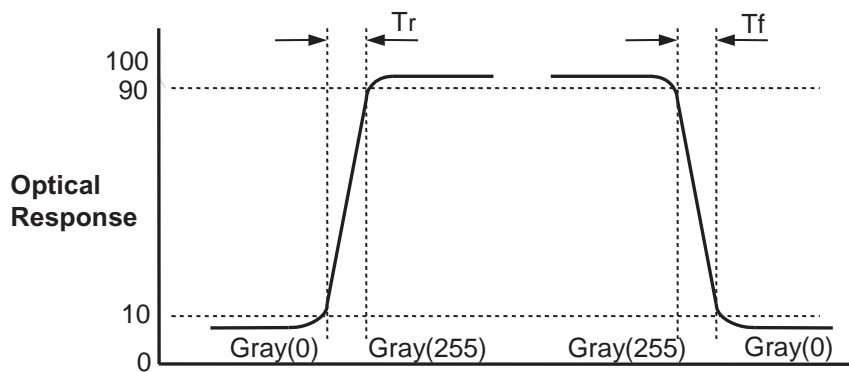

FIG. 9 Response Time

Dimension of viewing angle range

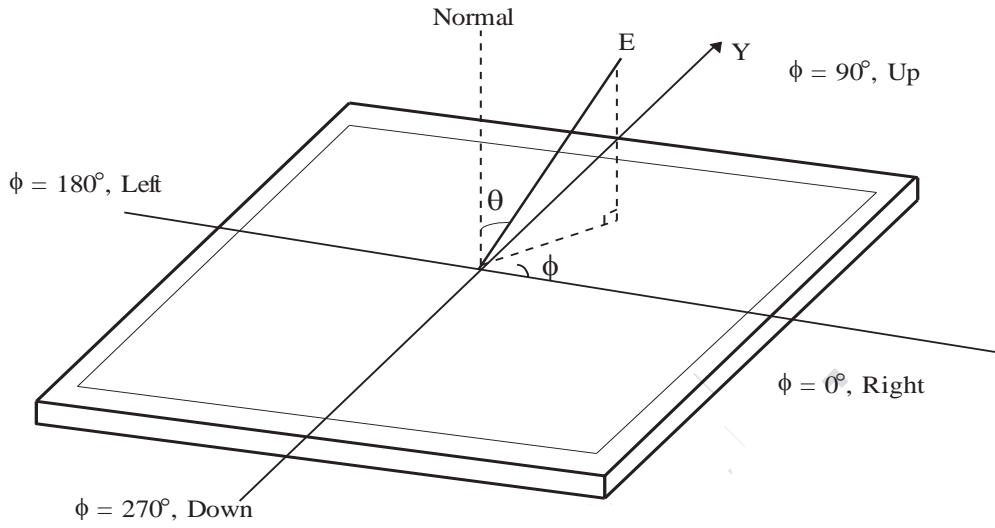

FIG. 4 Viewing Angle

## 5. Mechanical Characteristics

Table 13 provides general mechanical characteristics.

Item	Value	
Outline Dimension	Horizontal	1461mm
	Vertical	843.1mm
	Depth	58mm
Active Display Area	Horizontal	1428.48 mm
	Vertical	803.52 mm
Weight	14.28Kg (Typ.), 15 kg (Max.)	

## 6. Reliability

**Table 14. ENVIRONMENT TEST CONDITION**

No.	Test Item	Condition
1	High temperature storage test	Ta= 60°C 90% 240h
2	Low temperature storage test	Ta= -20°C 240h
3	High temperature operation test	Ta= 50°C 50%RH 500h
4	Low temperature operation test	Ta= 0°C 500h
5	Humidity condition Operation	Ta= 40 °C, 90%RH
6	Altitude operating storage / shipment	0 – 16,400 ft 0 - 40,000 ft
7	Vibration test (non-operating)	Wave form : Random Vibration Level 1.0Grms Bandwidth : 10 ~ 300Hz Duration : X, Y, Z Each direction Per 10min
8	Shock test (non-operating)	Shock Level : 20Grms Waveform : Half Sine Wave, 11ms Duration : X, Y, Z One time each direction
9	Panel Push Test (Module Condition)	Max 6KgF

notes : 1. Before and after Reliability test, LCM should be operated with normal function.

## 7. International Standards

### 7-1. Safety

- a) UL 60065, Underwriters Laboratories Inc.  
Audio, Video and Similar Electronic Apparatus - Safety Requirements.
- b) CAN/CSA-C22.2 No. 60065-03, Canadian Standards Association.  
Audio, Video and Similar Electronic Apparatus - Safety Requirements.
- c) EN 60065, European Committee for Electrotechnical Standardization (CENELEC).  
Audio, Video and Similar Electronic Apparatus - Safety Requirements.
- d) IEC 60065, The International Electrotechnical Commission (IEC).  
Audio, Video and Similar Electronic Apparatus - Safety Requirements.

### 7-2. EMC

- a) ANSI C63.4 "American National Standard for Methods of Measurement of Radio-Noise Emissions from Low-Voltage Electrical and Electronic Equipment in the Range of 9 kHz to 40 GHz." American National Standards Institute (ANSI), 2003.
- b) CISPR 22 "Information technology equipment – Radio disturbance characteristics – Limit and methods of measurement." International Special Committee on Radio Interference (CISPR), 2005.
- c) CISPR 13 "Sound and television broadcast receivers and associated equipment – Radio disturbance characteristics – Limits and method of measurement." International Special Committee on Radio Interference (CISPR), 2006.

### 7-3. Environment

- a) RoHS, Directive 2011/65/EU of the European Parliament and of the council of 8 June 2011

## 9. Precautions

Please pay attention to the followings when you use this TFT LCD module.

### 9-1. Mounting Precautions

- (1) You must mount a module using specified mounting holes (Details refer to the drawings).
- (2) You should consider the mounting structure so that uneven force (ex. Twisted stress, Concentrated stress) is not applied to the module. And the case on which a module is mounted should have sufficient strength so that external force is not transmitted directly to the module.
- (3) Please attach the surface transparent protective plate to the surface in order to protect the polarizer. Transparent protective plate should have sufficient strength in order to resist external force.
- (4) You should adopt radiation structure to satisfy the temperature specification.
- (5) Acetic acid type and chlorine type materials for the cover case are not desirable because the former generates corrosive gas of attacking the polarizer at high temperature and the latter causes circuit break by electro-chemical reaction.
- (6) Do not touch, push or rub the exposed polarizers with glass, tweezers or anything harder than HB pencil lead. And please do not rub with dust clothes with chemical treatment. Do not touch the surface of polarizer for bare hand or greasy cloth. (Some cosmetics are detrimental to the polarizer.)
- (7) When the surface becomes dusty, please wipe gently with absorbent cotton or other soft materials like chamois soaks with petroleum benzine. Normal-hexane is recommended for cleaning the adhesives used to attach front / rear polarizers. Do not use acetone, toluene and alcohol because they cause chemical damage to the polarizer
- (8) Wipe off saliva or water drops as soon as possible. Their long time contact with polarizer causes deformations and color fading.
- (9) Do not open the case because inside circuits do not have sufficient strength.

### 9-2. Operating Precautions

- (1) Response time depends on the temperature. (In lower temperature, it becomes longer.)
- (2) Brightness depends on the temperature. (In lower temperature, it becomes lower.)  
And in lower temperature, response time (required time that brightness is stable after turned on) becomes longer
- (3) Be careful for condensation at sudden temperature change. Condensation makes damage to polarizer or electrical contacted parts. And after fading condensation, smear or spot will occur.
- (4) When fixed patterns are displayed for a long time, remnant image is likely to occur.
- (5) Module has high frequency circuits. Sufficient suppression to the electromagnetic interference shall be done by system manufacturers. Grounding and shielding methods may be important to minimize the interference.
- (6) Please do not give any mechanical and/or acoustical impact to LCM. Otherwise, LCM can't be operated its full characteristics perfectly.
- (7) A screw which is fastened up the steels should be a machine screw.  
(if not, it can cause conductive particles and deal LCM a fatal blow)
- (8) Please do not set LCD on its edge.
- (9) The conductive material and signal cables are kept away from LED driver inductor to prevent abnormal display, sound noise and temperature rising.

### 9-3. Electrostatic Discharge Control

Since a module is composed of electronic circuits, it is not strong to electrostatic discharge. Make certain that treatment persons are connected to ground through wrist band etc. And don't touch interface pin directly.

### 9-4. Precautions for Strong Light Exposure

Strong light exposure causes degradation of polarizer and color filter.

### 9-5. Storage

When storing modules as spares for a long time, the following precautions are necessary.

- (1) Store them in a dark place. Do not expose the module to sunlight or fluorescent light. Keep the temperature between 5°C and 35°C at normal humidity.
- (2) The polarizer surface should not come in contact with any other object.  
It is recommended that they be stored in the container in which they were shipped.
- (3) Storage condition is guaranteed under packing conditions.
- (4) The phase transition of Liquid Crystal in the condition of the low or high storage temperature will be recovered when the LCD module returns to the normal condition.

### 9-6. Handling Precautions for Protection Film

- (1) The protection film is attached to the bezel with a small masking tape.  
When the protection film is peeled off, static electricity is generated between the film and polarizer.  
This should be peeled off slowly and carefully by people who are electrically grounded and with well ion-blown equipment or in such a condition, etc.
- (2) When the module with protection film attached is stored for a long time, sometimes there remains a very small amount of glue still on the bezel after the protection film is peeled off.
- (3) You can remove the glue easily. When the glue remains on the bezel surface or its vestige is recognized, please wipe them off with absorbent cotton waste or other soft material like chamois soaked with normal-

# APPENDIX- III

■ Required signal assignment for Flat Link (Thine : THCV215) Transmitter

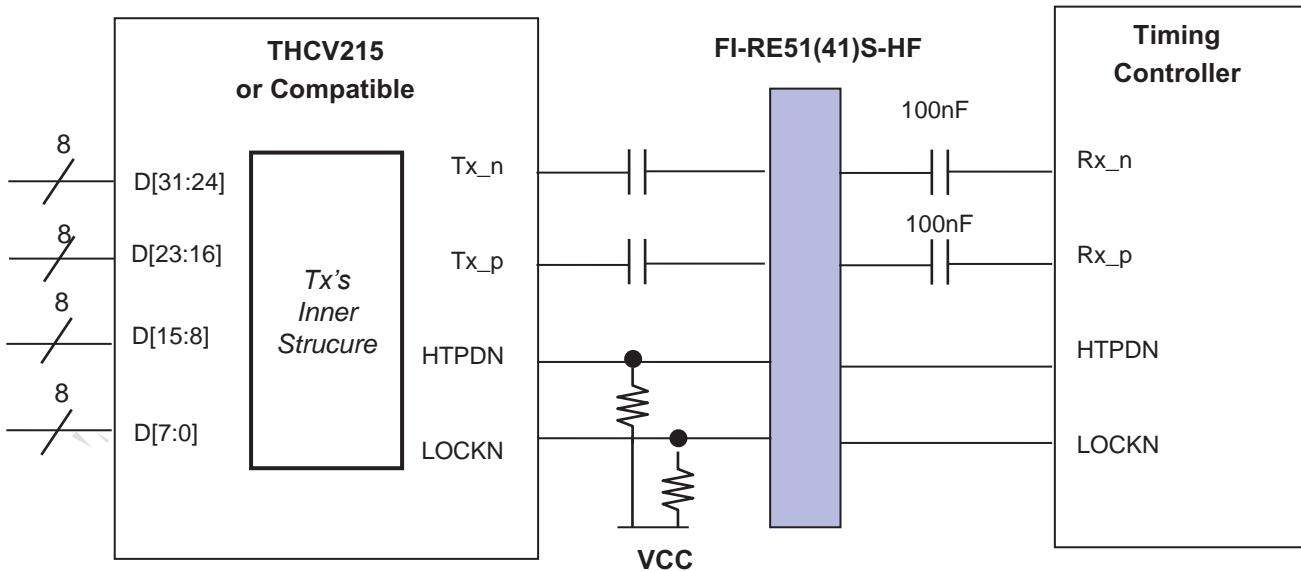
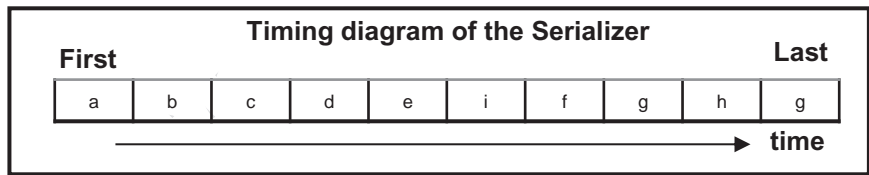
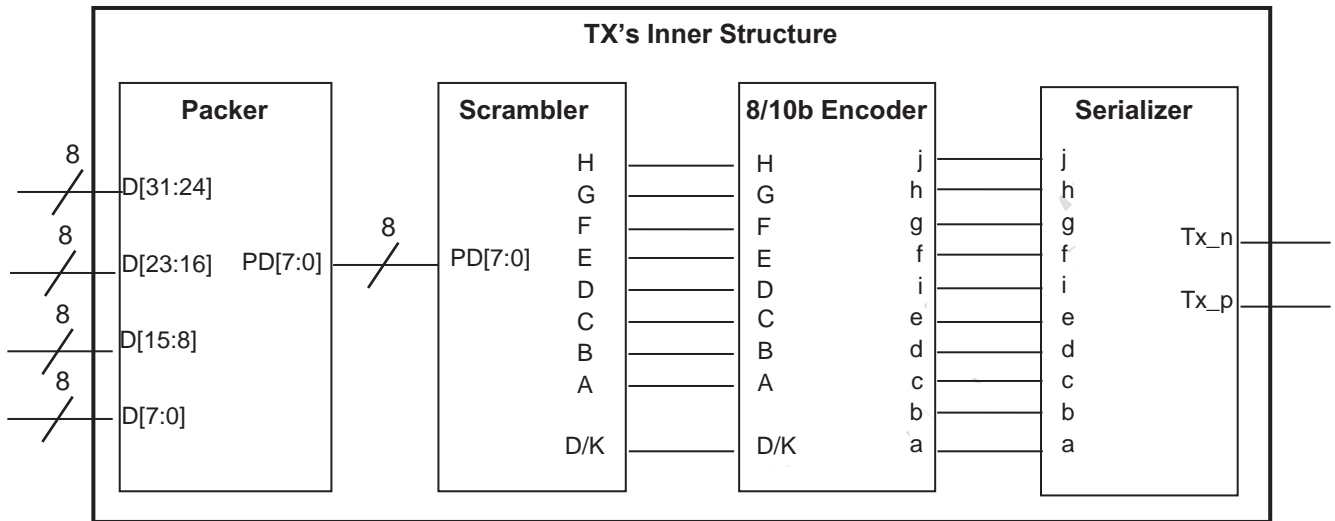

- notes: 1. The LCD module uses a 100 nF capacitor on positive and negative lines of each receiver input.  
 2. Refer to Vx1 Transmitter Data Sheet for detail descriptions. (THCV215 or Compatible)  
 3. About Module connector pin configuration, Please refer to the Page 7



# APPENDIX- IV-1

■ Option Pin Circuit Block Diagram

1) Circuit Block Diagram of M plus mode Selection pin

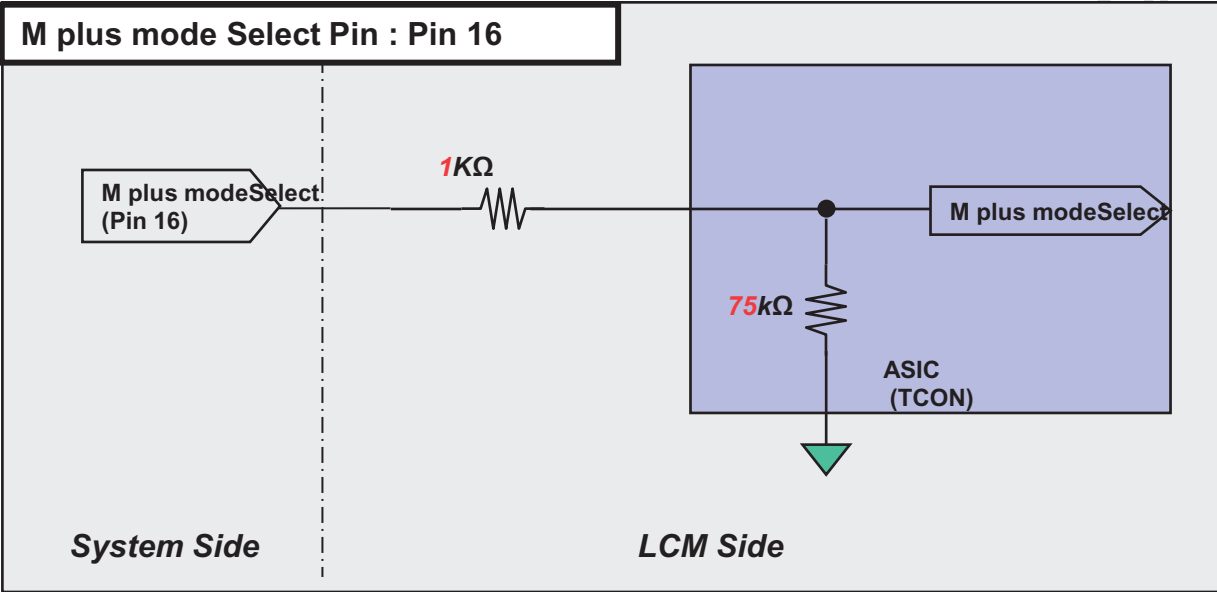

2) Circuit Block Diagram of M plus Enable pin

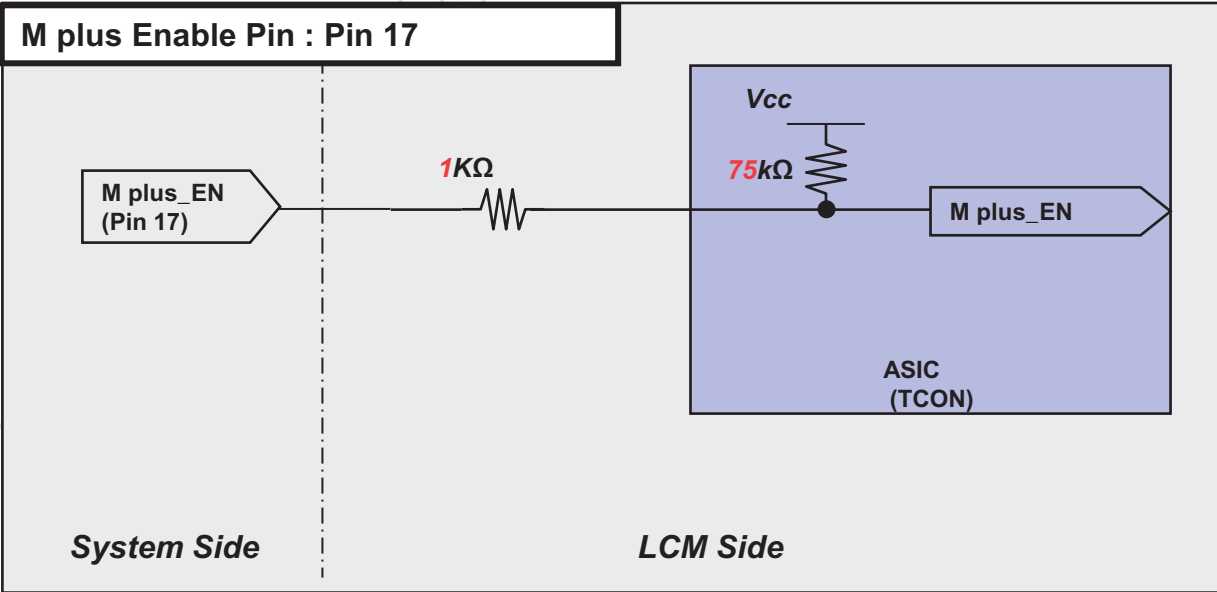

# APPENDIX- IV-2

■ Option Pin Circuit Block Diagram

3) Circuit Block Diagram of Bit Selection pin

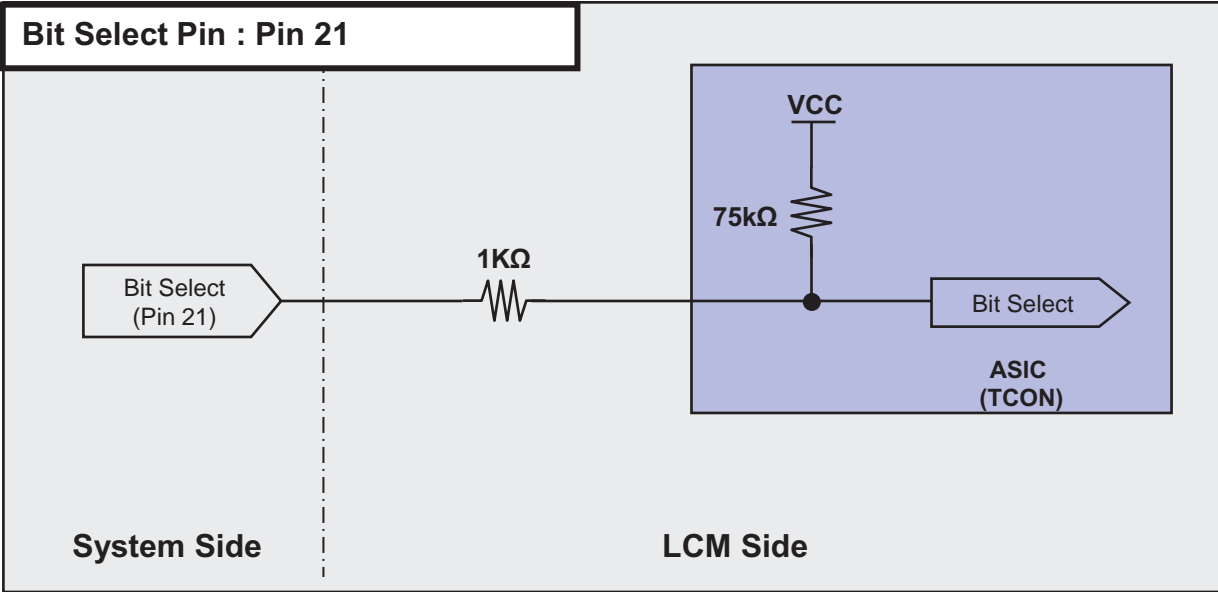

4) Circuit Block Diagram of L-Dim Enable Selection pin

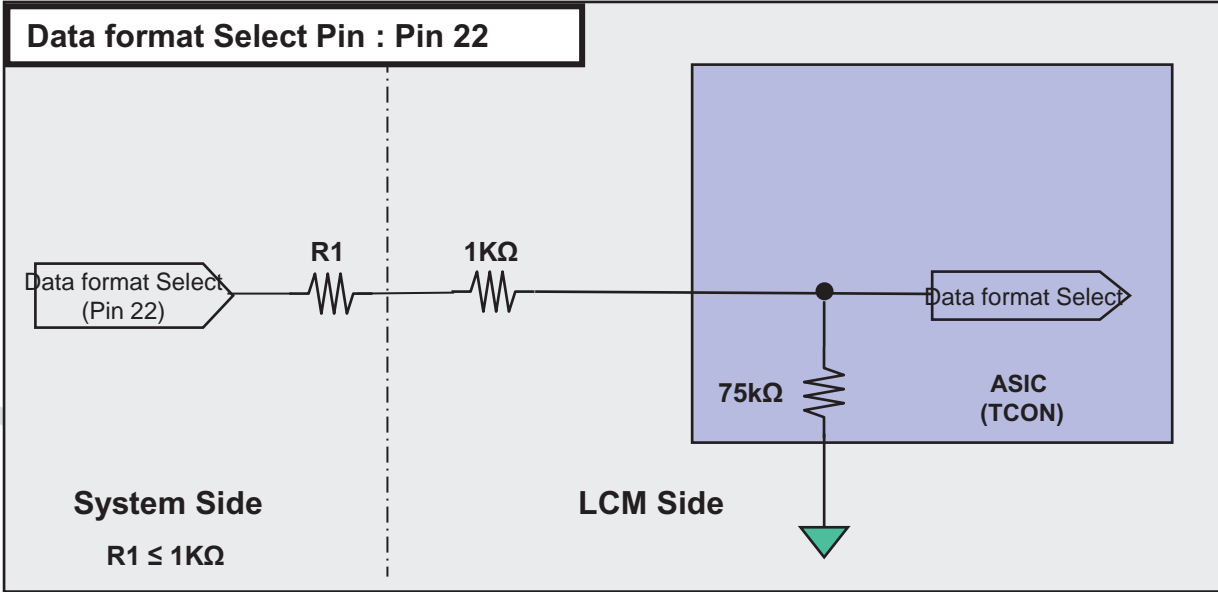

# APPENDIX- IV-3

■ Option Pin Circuit Block Diagram

3) Circuit Block Diagram of AGP Selection pin

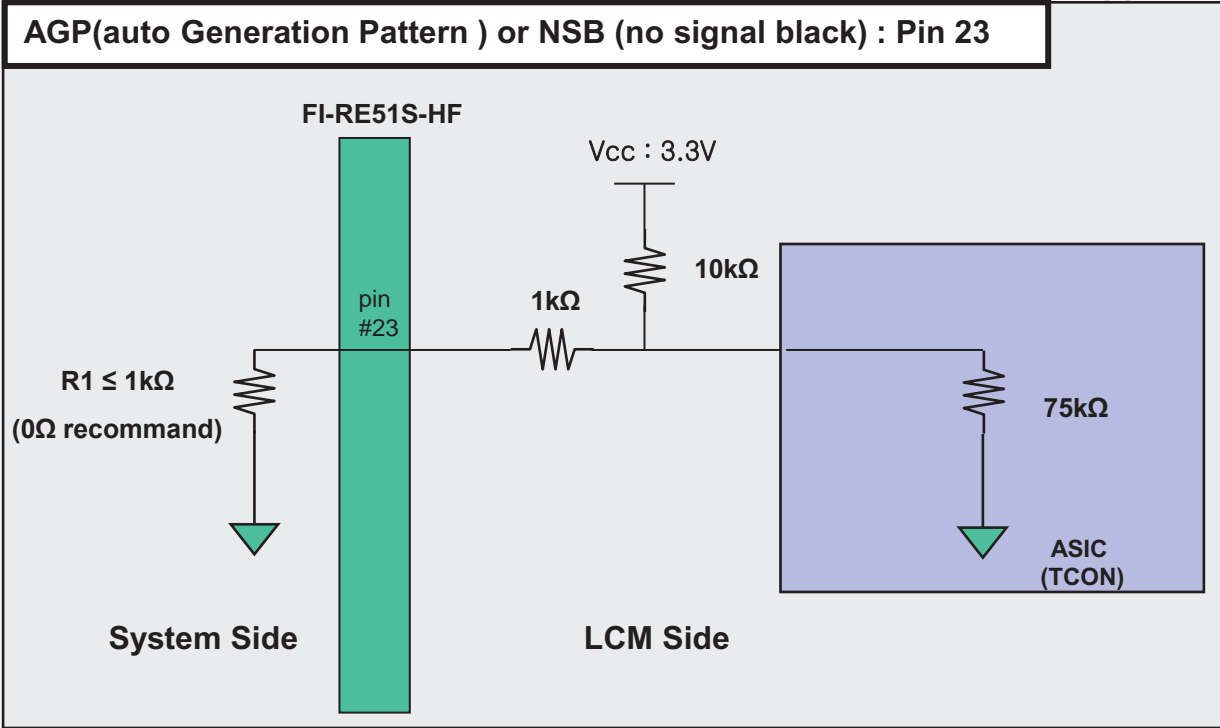

# APPENDIX- V

■ LED Array Electrical Spec

Item	Condition	Min	Typ	Max	Unit	Remark
Forward voltage(Vf)	Ifm=330mA	-	185.4	-	V	Ta=25℃
$\Delta Vf^{*1}$		-	-	4.9	V	

■ Forward Current vs. Forward Voltage

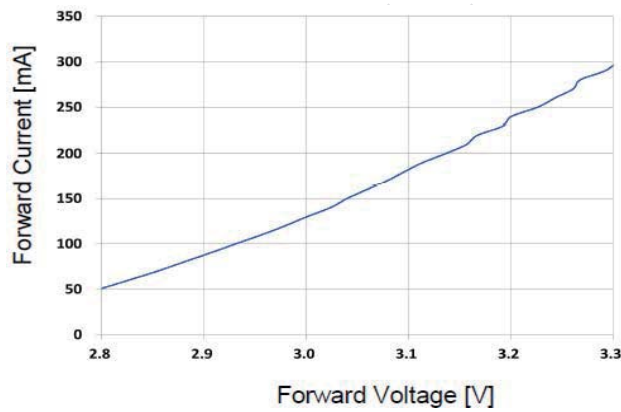

■ Ambient Temperature vs. Forward Voltage

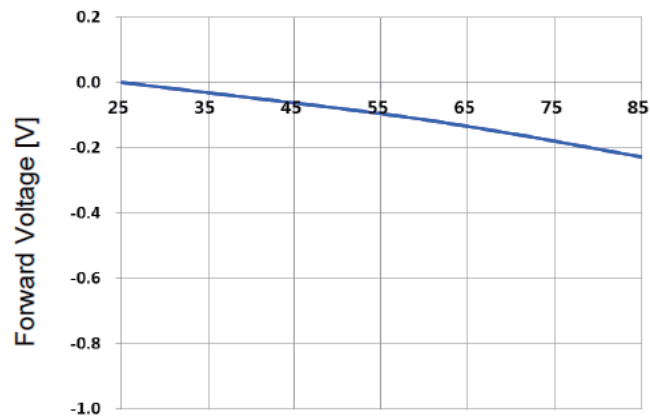

# APPENDIX- VI

■ input mode of pixel data

Mode 1 : Non-Division				Mode 2 : 2 Division			
Lane	1 <sup>st</sup> Data	2 <sup>nd</sup> Data	Data#	Lane	1 <sup>st</sup> Data	2 <sup>nd</sup> Data	Data#
Lane0	1	9	3833	Lane0	1	5	1917
Lane1	2	10	3834	Lane1	2	6	1918
Lane2	3	11	3835	Lane2	3	7	1919
Lane3	4	12	3836	Lane3	4	8	1920
Lane4	5	13	3837	Lane4	1921	1925	3837
Lane5	6	14	3838	Lane5	1922	1926	3838
Lane6	7	15	3839	Lane6	1923	1927	3839
Lane7	8	16	3840	Lane7	1924	1928	3840