

# Product Specification

- ( ) Product Information
- ( ) Preliminary Specification
- (  ) Approval Specification

*Any modification of Spec is not allowed without SDC's permission.*

CUSTOMER	R/A Customer
DATE OF ISSUE	2019/011/1

MODEL NO.	IS320ENT-
EXTENSION CODE	-V(0)

<b>Customer Approval &amp; Feedback</b>

Approved by	
Prepared by	Luo Cianbin

# SPECIFICATION FOR APPROVAL

- Preliminary Specification
- Final Specification

This specification is applicable to 32 "1500cd/m<sup>2</sup>

If there is any change to the specific panel information, we will inform you

## 1. General Description

The IS320ENT is a Color Active Matrix Liquid Crystal Display with an integral Light Emitting Diode (LED) backlight system. The matrix employs a-Si Thin Film Transistor as the active element.

It is a transmissive display type which is operating in the normally black mode. It has a 32.0 inch diagonally measured active display area with WUXGA resolution (1080 vertical by 1920 horizontal pixel array). Each pixel is divided into Red, Green and Blue sub-pixels or dots which are arrayed in vertical stripes. Gray scale or the luminance of the sub-pixel color is determined with a 8-bit gray scale signal for each dot. Therefore, it can present a palette of more than 16.7Million colors.

It has been designed to apply the 8-bit 2-port LVDS interface.

It is intended to support Commercial Display where high brightness, super wide viewing angle, high color gamut, high color depth and fast response time are important.

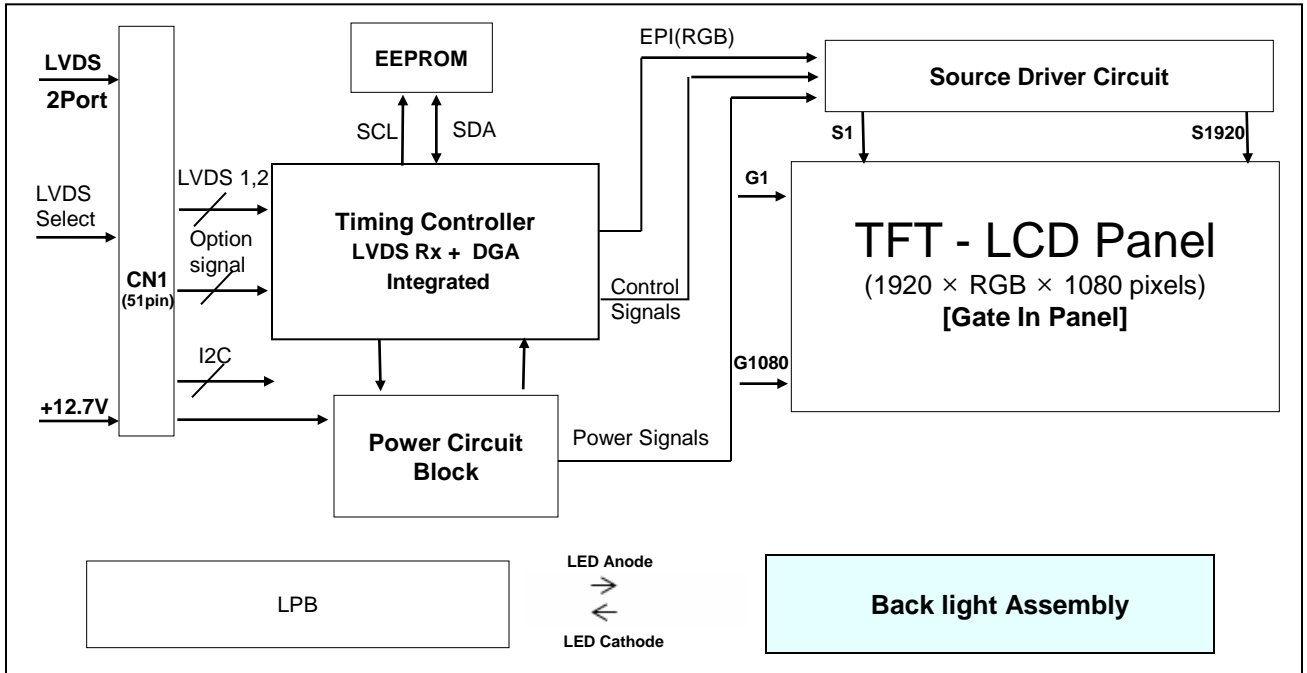

## General Features

Active Screen Size	31.5inches diagonal
Outline Dimension	725.2(H) x 422.7(V) x 40.0(D) (Typ.)58.0(D) (Max) mm
Pixel Pitch	0.4902 mm x 0.4902 mm
Pixel Format	1920 horiz. by 1080 vert. Pixels, RGB stripe arrangement
Color Depth	8bit, 16.7 Million colors
Luminance, White	1500cd/m <sup>2</sup> (Center 1point ,Typ.)
Viewing Angle (CR>10)	Viewing angle free ( R/L 178 (Min.), U/D 178 (Min.))
TotalPower Consumption	1500cd/m <sup>2</sup> =75W
Weight	6.56kg(Typ.) 6.6 kg (Max)
Display Mode	Transmissive mode, Normally black
Surface Treatment	Hard coating(3H), Anti-glare treatment of the front polarizer (Haze 1%(Typ.))
Possible Display Type	Landscape and Portrait Enabled

## 2. Absolute Maximum Ratings

The following items are maximum values which, if exceeded, may cause faulty operation or permanent damage to the LCD module.

**Table 1. ABSOLUTE MAXIMUM RATINGS (Only Panel and Circuit Part of LCD Module)**

Parameter		Symbol	Value		Unit	Note
			Min	Max		
Power Input Voltage	LCD Circuit	V <sub>LCD</sub>	-0.3	+14.0	VDC	1
LED Input Voltage	Forward Voltage	V <sub>F</sub>	-	+130.5	VDC	
T-Con Option Selection Voltage		V <sub>LOGIC</sub>	-0.3	+4.0	VDC	
Operating Temperature		T <sub>OP</sub>	0	+50	°C	2,3
Storage Temperature		T <sub>ST</sub>	-20	+60	°C	
Panel Front Temperature		T <sub>SUR</sub>	-	+68	°C	4
Operating Ambient Humidity		H <sub>OP</sub>	10	90	%RH	2,3
Storage Humidity		H <sub>ST</sub>	5	90	%RH	

1. Ambient temperature condition ( $T_a = 25 \pm 2 \text{ }^\circ\text{C}$ )
2. Temperature and relative humidity range are shown in the figure below.  
Wet bulb temperature should be Max 39°C, and no condensation of water.
3. Gravity mura can be guaranteed below 40°C condition.
4. The maximum operating temperatures is based on the test condition that the surface temperature of display area is less than or equal to 68°C with LCD module alone in a temperature controlled chamber. Thermal management should be considered in final product design to prevent the surface temperature of display area from being over 68°C. The range of operating temperature may be degraded in case of improper thermal management in final product design.

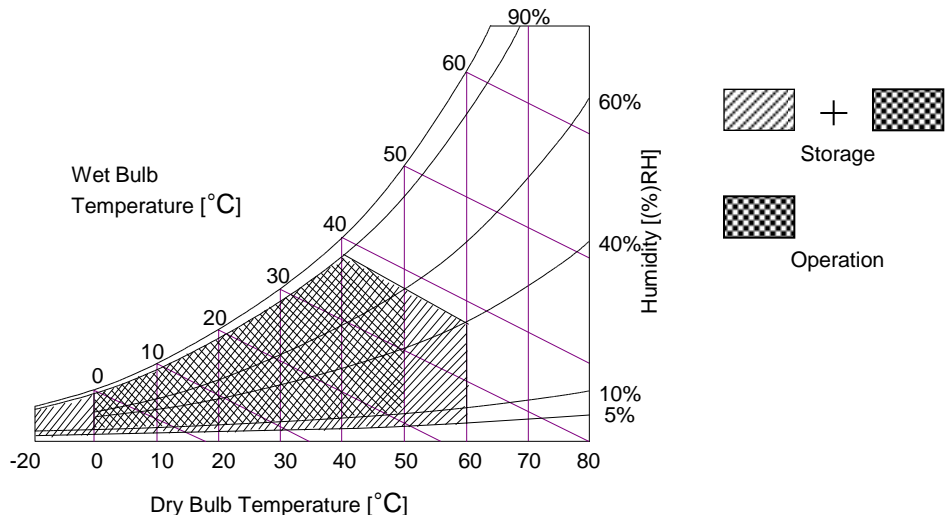

### 3. Electrical Specifications

#### 3-1. Electrical Characteristics

It requires two power inputs. One is employed to power for the LCD circuit. The other is used for the LED backlight and LED Driver circuit.

**Table 2. ELECTRICAL CHARACTERISTICS**

Parameter		Symbol	Value			Unit	Note
			Min	Typ	Max		
<b>Circuit :</b>							
Power Input Voltage		V <sub>LCD</sub>	10.8[TBD]	12.7	14.0	V <sub>DC</sub>	
Power Input Current		I <sub>LCD</sub>	-	350	455	mA	1
			-	550	715	mA	2
T-CON Option Selection Voltage	Input High Voltage	V <sub>IH</sub>	1.62	-	1.98	V <sub>DC</sub>	
	Input Low Voltage	V <sub>IL</sub>	0	-	0.54	V <sub>DC</sub>	
Power Consumption		P <sub>LCD</sub>	-	4.2	5.5	Watt	1
Rush current		I <sub>RUSH</sub>	-	-	5.0	A	3

notes

1. The specified current and power consumption are under the  $V_{LCD}=12.0V$ ,  $T_a=25 \pm 2^\circ C$ ,  $f_v=60Hz$  condition, and mosaic pattern(8 x 6) is displayed and  $f_v$  is the frame frequency.
2. The current is specified at the maximum current pattern.
3. The duration of rush current is about 2ms and rising time of power input is 0.5ms (min.).
4. Ripple voltage level is recommended under  $\pm 5\%$  of typical voltage.

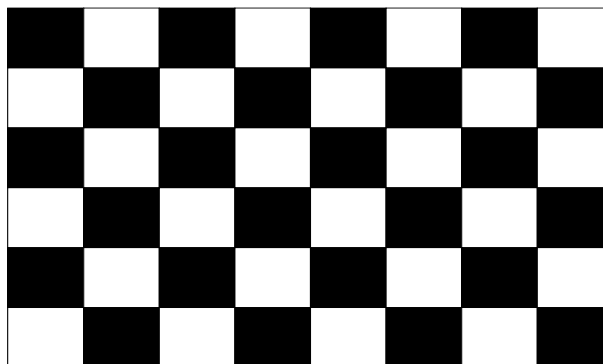

White : 255 Gray  
Black : 0 Gray

**Mosaic Pattern(8 x 6)**

### 3-2. Interface Connections

This LCD module employs three kinds of interface connection, 51-pin connector is used for the module electronics.

#### 3-2-1. LCD Module

- LCD Connector(CN1): FI-RXE51S-HF(manufactured by JAE) or compatible
- Mating Connector : FI-R51HL(JAE) or compatible

**Table 4. MODULE CONNECTOR(CN1) PIN CONFIGURATION**

No	Symbol	Description	No	Symbol	Description
1	NC or GND	No Connection or Ground (Note 4)	27	NC	No connection
2	NC	No Connection (Note 4)	28	R2AN	SECOND LVDS Receiver Signal (A-)
3	NC	No Connection (Note 4)	29	R2AP	SECOND LVDS Receiver Signal (A+)
4	NC	No Connection (Note 4)	30	R2BN	SECOND LVDS Receiver Signal (B-)
5	NC	No Connection (Note 4)	31	R2BP	SECOND LVDS Receiver Signal (B+)
6	NC	No Connection (Note 4)	32	R2CN	SECOND LVDS Receiver Signal (C-)
7	LVDS Select	'H' =JEIDA , 'L' or NC = VESA	33	R2CP	SECOND LVDS Receiver Signal (C+)
8	NC	No Connection (Note 4)	34	GND	Ground
9	NC	No Connection (Note 4)	35	R2CLKN	SECOND LVDS Receiver Clock Signal(-)
10	NC	No Connection (Note 4)	36	R2CLKP	SECOND LVDS Receiver Clock Signal(+)
11	GND	Ground	37	GND	Ground
12	R1AN	FIRST LVDS Receiver Signal (A-)	38	R2DN	SECOND LVDS Receiver Signal (D-)
13	R1AP	FIRST LVDS Receiver Signal (A+)	39	R2DP	SECOND LVDS Receiver Signal (D+)
14	R1BN	FIRST LVDS Receiver Signal (B-)	40	NC	No connection
15	R1BP	FIRST LVDS Receiver Signal (B+)	41	NC	No connection
16	R1CN	FIRST LVDS Receiver Signal (C-)	42	NC or GND	No Connection or Ground
17	R1CP	FIRST LVDS Receiver Signal (C+)	43	NC or GND	No Connection or Ground
18	GND	Ground	44	GND	Ground (Note 5)
19	R1CLKN	FIRST LVDS Receiver Clock Signal(-)	45	GND	Ground
20	R1CLKP	FIRST LVDS Receiver Clock Signal(+)	46	GND	Ground
21	GND	Ground	47	NC	No connection
22	R1DN	FIRST LVDS Receiver Signal (D-)	48	VLCD	Power Supply +12.0V
23	R1DP	FIRST LVDS Receiver Signal (D+)	49	VLCD	Power Supply +12.0V
24	NC	No connection	50	VLCD	Power Supply +12.0V
25	NC	No connection	51	VLCD	Power Supply +12.0V
26	NC or GND	No Connection or Ground	-	-	-

- Note
1. All GND(ground) pins should be connected together to the LCD module's metal frame.
  2. All VLCD (power input) pins should be connected together.
  3. All Input levels of LVDS signals are based on the **EIA 644** Standard.
  4. #1~#6 & #8~#10 NC (No Connection): These pins are used only for LGD (Do not connect)
  5. Specific pin No. **#44** is used for "No signal detection" of system signal interface.  
It should be GND for NSB(No Signal Black) during the system interface signal is not.  
If this pin is "H", LCD Module displays AGP(Auto Generation Pattern).

**3-2-2. Backlight Module**

Table 3. ELECTRICAL CHARACTERISTICS (Continue)

parameter	Symbol	VALUES			Unit	Notes	
		MIN	TYP	MAX			
Power supply input voltage	VBL	23	24	25	VDC	1	
Power supply input current	IBL_A		3.1		A	1500	
Power consumption	PBL		75		W	cd/m <sup>2</sup>	
Power supply input current	IBL_A		4.2		A	2000	
Power consumption	PBL		99		W	cd/m <sup>2</sup>	
Power supply input current	IBL_A		6.25		A	2500	
Power consumption	PBL		150		W	cd/m <sup>2</sup>	
Power supply input current	IBL_A		7.5		A	3000	
Power consumption	PBL		180		W	cd/m <sup>2</sup>	
Input signal for inverter control	on	V on	2.5		5	V	
	off	V off	0		0.5	V	
Brightness adjust	EXTVBR-B	30			100	%	Automatic sensitization control

◆ Rear view of LCM

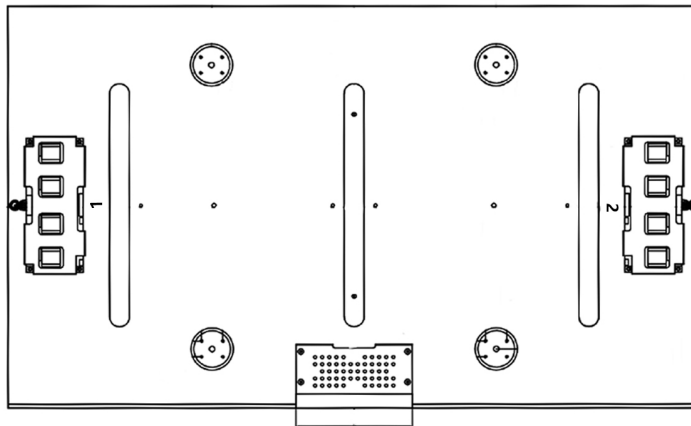

Note: We may change it according to your actual needs. There may be no option 2

## Product Specification

### 2、LED 恒流板接口

#### 2.1 Board A

P001 PH2.0-14PIN (2.0mm\*14)      P002 PH2.0-2PIN (2.0mm\*2)

Pin NO.	symbol	P001 Description	P002 Description	note
1	VCC	Power Supply Voltage	Light sensor negative pole -	
2	VCC	Power Supply Voltage	Light sensor positive pole +	
3	VCC	Power Supply Voltage		
4	VCC	Power Supply Voltage		
5	VCC	Power Supply Voltage		
6	GND	Power ground		
7	GND	Power ground		
8	GND	Power ground		
9	GND	Power ground		
10	GND	Power ground		
11	NC	Not connect		
12	ON/OFF	Output enable signal		
13	NC	Not connect		
14	NC	Not connect		

#### 2.2 Board B

P001 PH2.0-14PIN (2.0mm\*14)      P002 PH2.0-2PIN (2.0mm\*2)

Pin NO.	symbol	P001 Description	P002 Description	note
1	VCC	Power Supply Voltage	NC	
2	VCC	Power Supply Voltage	NC	
3	VCC	Power Supply Voltage		
4	VCC	Power Supply Voltage		
5	VCC	Power Supply Voltage		
6	GND	Power ground		
7	GND	Power ground		
8	GND	Power ground		
9	GND	Power ground		
10	GND	Power ground		
11	NC	Not connect		
12	NC	Not connect		
13	NC	Not connect		
14	NC	Not connect		



### 3-3. Signal Timing Specifications

Table 6 shows the signal timing required at the input of the LVDS transmitter. All of the interface signal timings should be satisfied with the following specification for normal operation.

**Table 6. TIMING TABLE for NTSC & PAL(DE Only Mode)**

ITEM		Symbol	Min	Typ	Max	Unit	notes
Horizontal	Display Period	tHV	960	960	960	tCLK	1920 / 2
	Blank	tHB	100	140	240	tCLK	1
	Total	tHP	1060	1100	1200	tCLK	
Vertical	Display Period	tVv	1080	1080	1080	Lines	
	Blank	tVB	20	45	300	Lines	1
	Total	tVP	1100	1125	1380	Lines	

ITEM		Symbol	Min	Typ	Max	Unit	notes
Frequency	DCLK	fCLK	60.00	74.25	78.00	MHz	
	Horizontal	fH	57.3	67.5	70	KHz	2
	Vertical	fV	47	60	63	Hz	2

Note: 1. The input of HSYNC & VSYNC signal does not have an effect on normal operation (DE Only Mode).  
If you use spread spectrum of EMI, add some additional clock to minimum value for clock margin.

2. The performance of the electro-optical characteristics may be influenced by variance of the vertical refresh rate and the horizontal frequency

3. Spread Spectrum Rate (SSR) for 50KHz ~ 100kHz Modulation Frequency(FMOD) is calculated by  $(7 - 0.06 * F_{mod})$ , where Modulation Frequency (FMOD) unit is KHz.  
LVDS Receiver Spread spectrum Clock is defined as below figure

※ Timing should be set based on clock frequency.

Product Specification

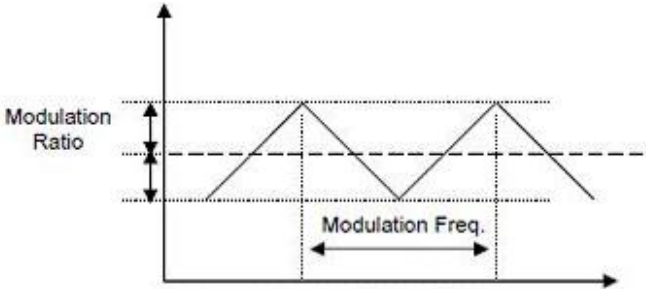
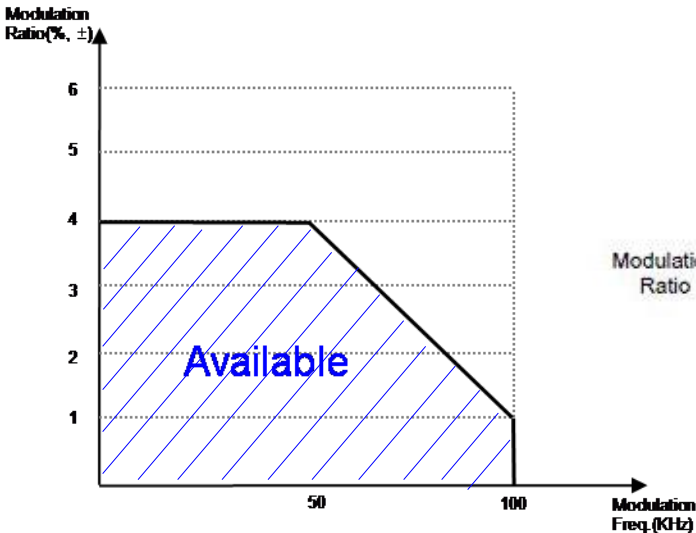

※ Please pay attention to the followings when you set Spread Spectrum Rate(SSR) and Modulation Frequency(FMOD)

- 1. Please set proper Spread Spectrum Rate(SSR) and Modulation Frequency (FMOD) of TV system LVDS output.
- 2. Please check FOS after you set Spread Spectrum Rate(SSR) and Modulation Frequency(FMOD) to avoid abnormal display. Especially, harmonic noise can appear when you use Spread Spectrum under FMOD 30 KHz.

### 3-4. LVDS Signal Specification

#### 3-4-1. LVDS Input Signal Timing Diagram

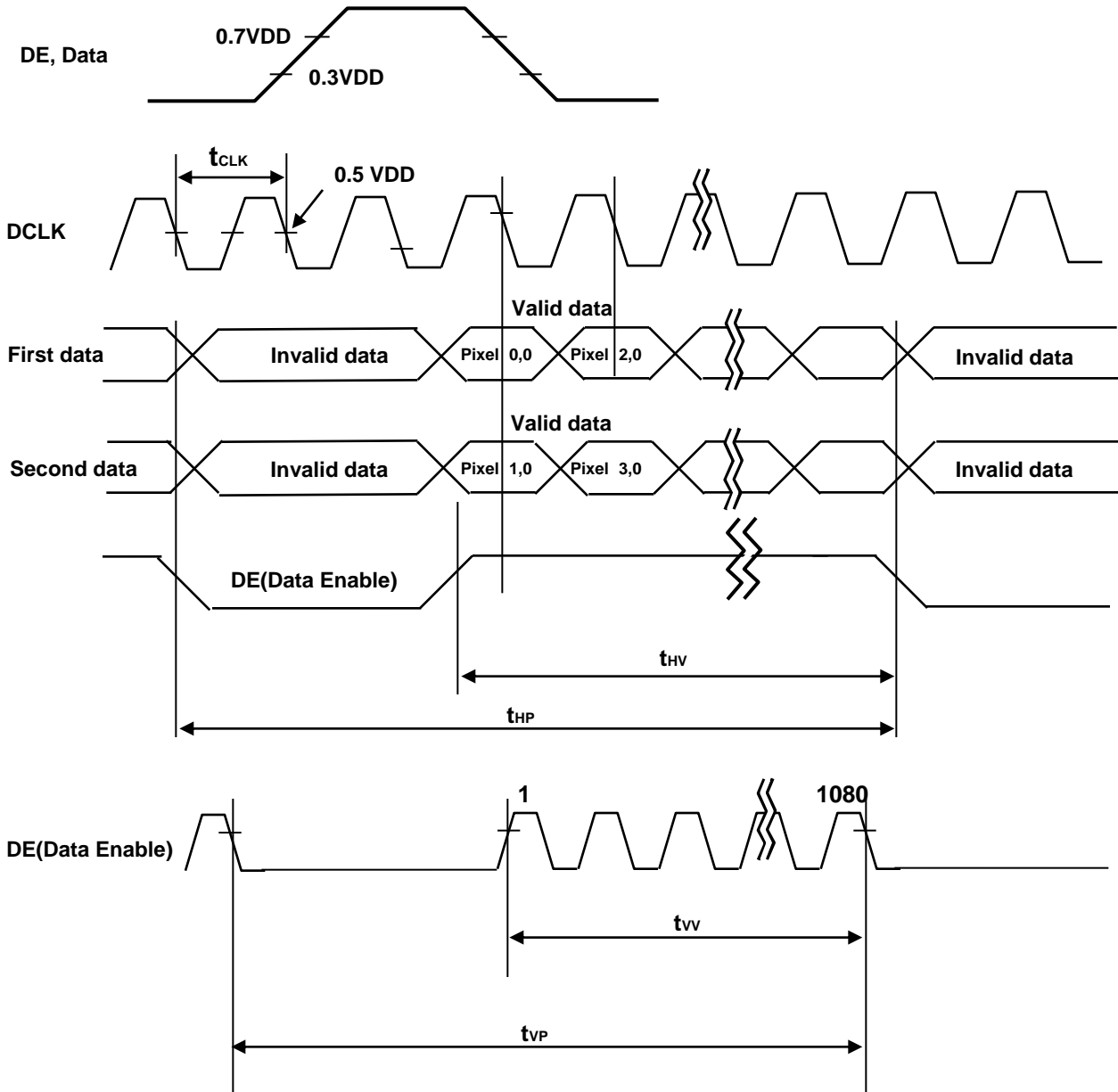

### 3-4-2. LVDS Input Signal Characteristics

#### 1) DC Specification

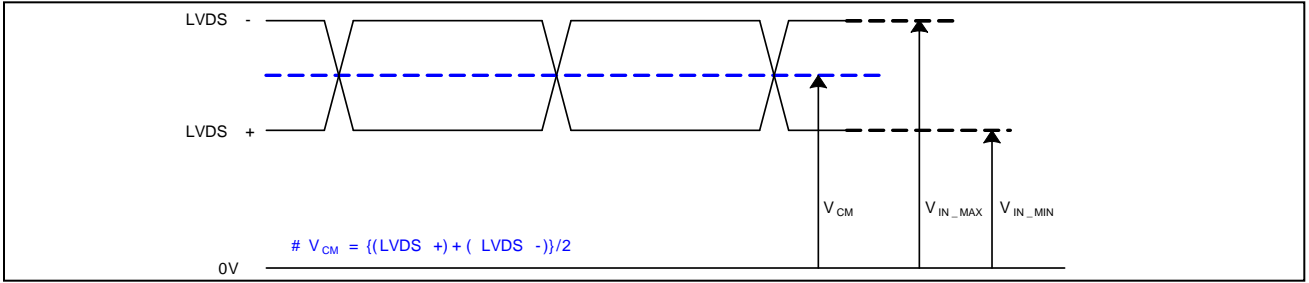

Description	Symbol	Min	Max	Unit	notes
LVDS Common mode Voltage	$V_{CM}$	1.0	1.5	V	-
LVDS Input Voltage Range	$V_{IN}$	0.7	1.8	V	-
Change in common mode Voltage	$\Delta V_{CM}$	-	250	mV	-

#### 2) AC Specification

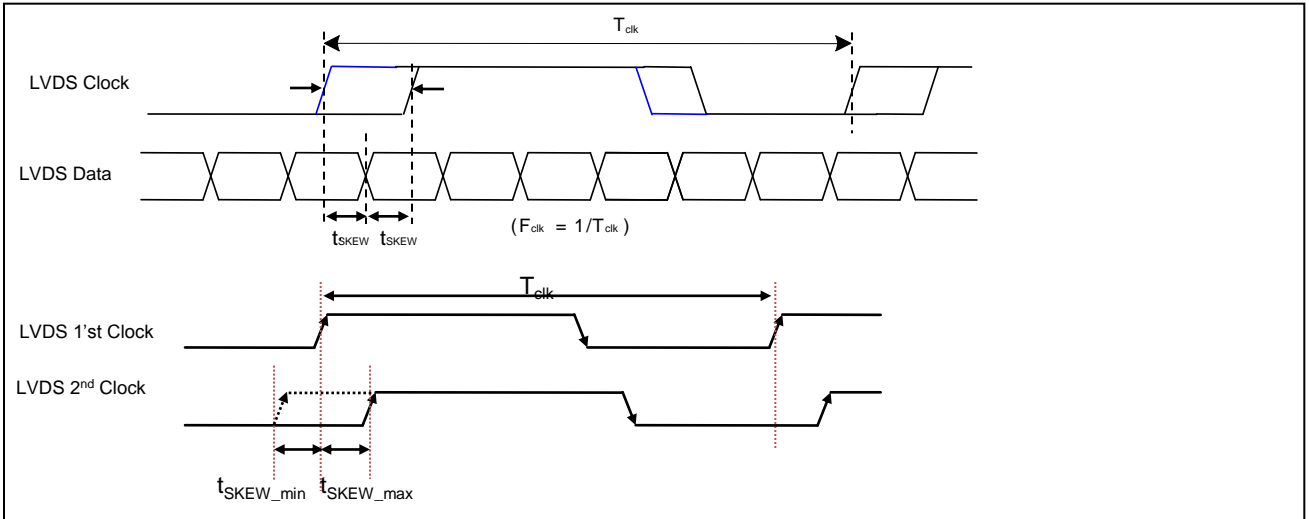

Description	Symbol	Min	Max	Unit	notes
LVDS Differential Voltage	$V_{TH}$	100	600	mV	Tested with Differential Probe 2
	$V_{TL}$	-600	-100	mV	
LVDS Clock to Data Skew	$t_{SKEW}$	-	$ (0.2 * T_{clk}) / 7 $	ps	-
Effective time of LVDS	$t_{eff}$	$ \pm 360 $	-	ps	-
LVDS Clock to Clock Skew (Even to Odd)	$t_{SKEW\_EO}$	-	$ 1/7 * T_{clk} $	ps	-

- notes 1. All Input levels of LVDS signals are based on the EIA 644 Standard.  
2. LVDS Differential Voltage is defined within  $t_{eff}$

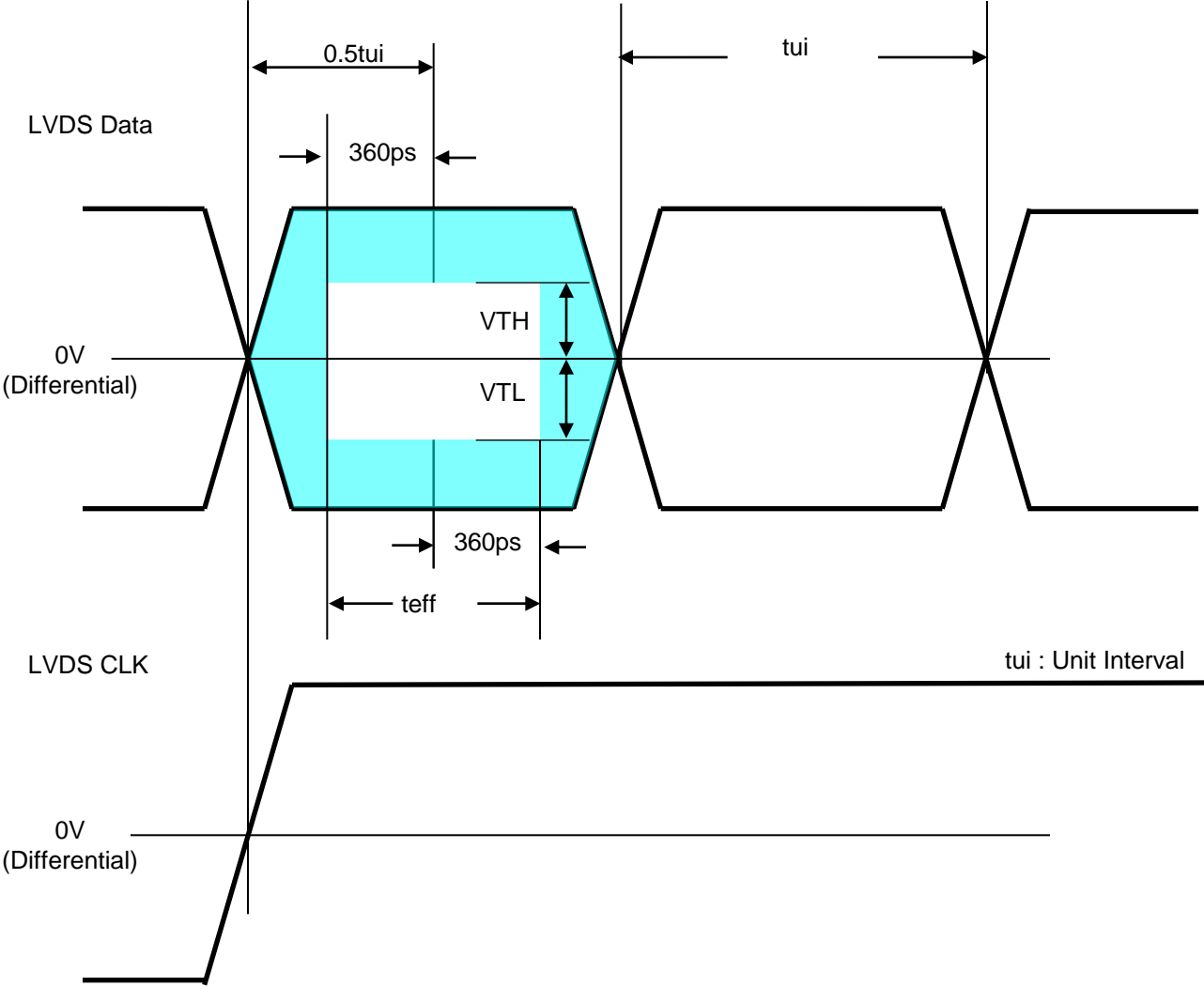

\* This accumulated waveform is tested with differential probe

### 3-5. Color Data Reference

The brightness of each primary color(red,green,blue) is based on the 8bit gray scale data input for the color. The higher binary input, the brighter the color. Table 7 provides a reference for color versus data input.

**Table 7. COLOR DATA REFERENCE**

Color		Input Color Data																							
		RED								GREEN								BLUE							
		MSB							LSB	MSB							LSB	MSB							LSB
		R7	R6	R5	R4	R3	R2	R1	R0	G7	G6	G5	G4	G3	G2	G1	G0	B7	B6	B5	B4	B3	B2	B1	B0
<b>Basic Color</b>	Black	0	0	0	0	0	0	0	0	0	0	0	0	0	0	0	0	0	0	0	0	0	0	0	0
	Red (255)	1	1	1	1	1	1	1	1	0	0	0	0	0	0	0	0	0	0	0	0	0	0	0	0
	Green (255)	0	0	0	0	0	0	0	0	1	1	1	1	1	1	1	1	0	0	0	0	0	0	0	0
	Blue (255)	0	0	0	0	0	0	0	0	0	0	0	0	0	0	0	0	1	1	1	1	1	1	1	1
	Cyan	0	0	0	0	0	0	0	0	1	1	1	1	1	1	1	1	1	1	1	1	1	1	1	1
	Magenta	1	1	1	1	1	1	1	1	0	0	0	0	0	0	0	0	1	1	1	1	1	1	1	1
	Yellow	1	1	1	1	1	1	1	1	1	1	1	1	1	1	1	1	0	0	0	0	0	0	0	0
	White	1	1	1	1	1	1	1	1	1	1	1	1	1	1	1	1	1	1	1	1	1	1	1	1
<b>RED</b>	RED (000)	0	0	0	0	0	0	0	0	0	0	0	0	0	0	0	0	0	0	0	0	0	0	0	0
	RED (001)	0	0	0	0	0	0	0	1	0	0	0	0	0	0	0	0	0	0	0	0	0	0	0	0
	...	...								...								...							
	RED (254)	1	1	1	1	1	1	1	0	0	0	0	0	0	0	0	0	0	0	0	0	0	0	0	0
	RED (255)	1	1	1	1	1	1	1	1	0	0	0	0	0	0	0	0	0	0	0	0	0	0	0	0
<b>GREEN</b>	GREEN (000)	0	0	0	0	0	0	0	0	0	0	0	0	0	0	0	0	0	0	0	0	0	0	0	0
	GREEN (001)	0	0	0	0	0	0	0	0	0	0	0	0	0	0	0	1	0	0	0	0	0	0	0	0
	...	...								...								...							
	GREEN (254)	0	0	0	0	0	0	0	0	1	1	1	1	1	1	1	0	0	0	0	0	0	0	0	0
	GREEN (255)	0	0	0	0	0	0	0	0	1	1	1	1	1	1	1	1	0	0	0	0	0	0	0	0
<b>BLUE</b>	BLUE (000)	0	0	0	0	0	0	0	0	0	0	0	0	0	0	0	0	0	0	0	0	0	0	0	0
	BLUE (001)	0	0	0	0	0	0	0	0	0	0	0	0	0	0	0	0	0	0	0	0	0	0	0	1
	...	...								...								...							
	BLUE (254)	0	0	0	0	0	0	0	0	0	0	0	0	0	0	0	0	1	1	1	1	1	1	1	0
	BLUE (255)	0	0	0	0	0	0	0	0	0	0	0	0	0	0	0	0	1	1	1	1	1	1	1	1

### 3-6. Power Sequence

#### 3-6-1. LCD Driving circuit

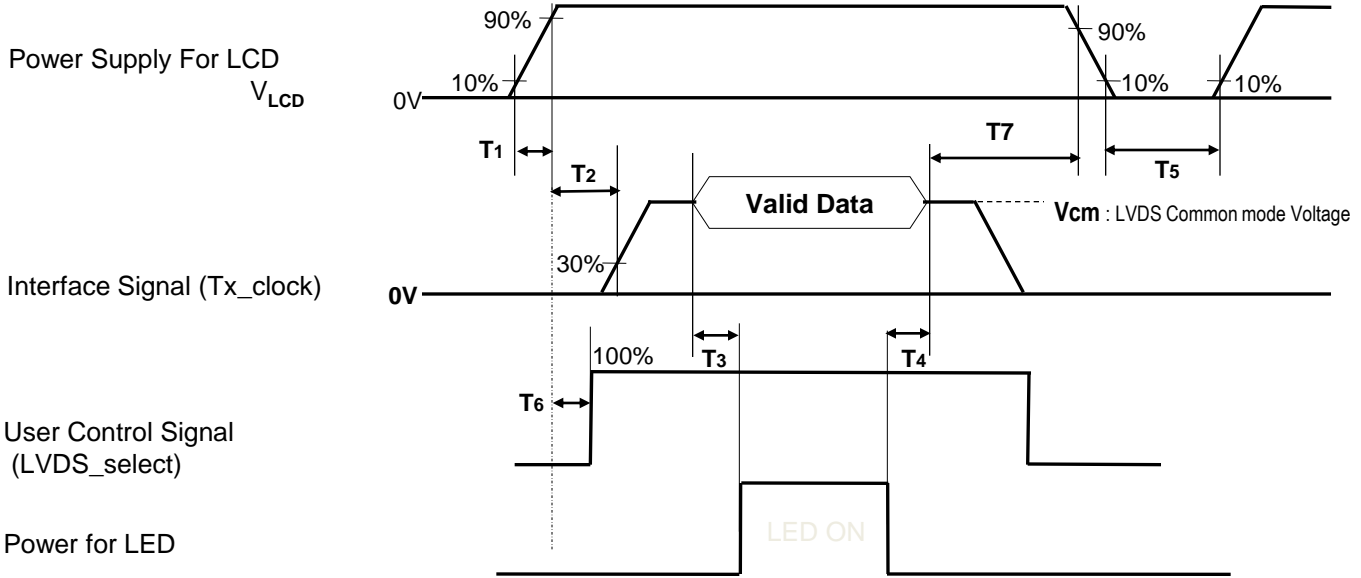

Table 8. POWER SEQUENCE

Parameter	Value			Unit	Notes
	Min	Typ	Max		
T1	0.5	-	20	ms	1
T2	0	-	-	ms	2
T3	400	-	-	ms	3
T4	100	-	-	ms	3
T5	1.0	-	-	s	4
T6	0	-	T2	ms	5
T7	0	-	-	ms	6

- Note :
1. Even though T1 is over the specified value, there is no problem if I2T spec of fuse is satisfied.
  2. If T2 is satisfied with specification after removing LVDS Cable, there is no problem.
  3. The T3 / T4 is recommended value, the case when failed to meet a minimum specification, abnormal display would be shown. There is no reliability problem.
  4. T5 should be measured after the Module has been fully discharged between power off and on period.
  5. If the on time of signals (Interface signal and user control signals) precedes the on time of Power ( $V_{LCD}$ ), it will be happened abnormal display. When T6 is NC status, T6 doesn't need to be measured.
  6. It is recommendation specification that T7 has to be 0ms as a minimum value.
- ※ Please avoid floating state of interface signal at invalid period.
  - ※ When the power supply for LCD (VLCD) is off, be sure to pull down the valid and invalid data to 0V.

#### 4. Optical Specification

Optical characteristics are determined after the unit has been 'ON' and stable in a dark environment at  $25 \pm 2^\circ\text{C}$ . The values are specified at 50cm from the LCD surface at a viewing angle of  $\Phi$  and  $\theta$  equal to  $0^\circ$ .

FIG. 1 shows additional information concerning the measurement equipment and method.

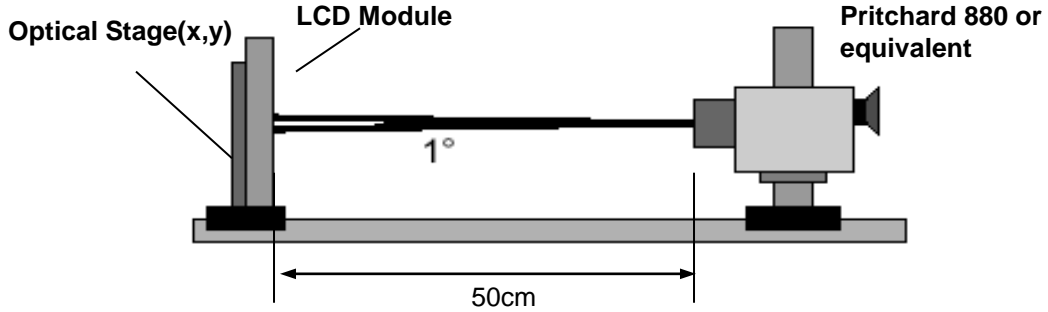

FIG. 1 Optical Characteristic Measurement Equipment and Method

$T_a = 25 \pm 2^\circ\text{C}$ ,  $V_{LCD} = 12.0\text{V}$ ,  $f_v = 60\text{Hz}$ ,  $D_{clk} = 74.25\text{MHz}$ ,  
Duty = 100%

Table 10. OPTICAL CHARACTERISTICS

Parameter	Symbol	Value			Unit	notes	
		Min	Typ	Max			
Contrast Ratio	CR	800	1100	-		1	
Surface Luminance, white	$L_{WH}$	0000	0000	-	cd/m <sup>2</sup>	2	
Luminance Variation	$\delta_{WHITE}$   9P	65	-	-		3	
Response Time	Gray to Gray (BW)	G to G BW	12(TBD)	16(TBD)	ms	4	
Color Coordinates [CIE1931]	RED	Rx		0.647(TBD)		5	
		Ry		0.334(TBD)			
	GREEN	Gx	Typ	0.306(TBD)	Typ		
		Gy	-0.03	0.601(TBD)	+0.03		
	BLUE	Bx		0.153(TBD)			
		By		0.052(TBD)			
	WHITE	Wx	Typ	0.281(TBD)	Typ		
		Wy	-0.03	0.288(TBD)	+0.03		
Color Temperature			10,000		K		
Color Gamut			68		%		
Viewing Angle (CR>10)							
	x axis, right( $\phi=0^\circ$ )	$\theta_r$	89	-	-	degree	6
	x axis, left ( $\phi=180^\circ$ )	$\theta_l$	89	-	-		
	y axis, up ( $\phi=90^\circ$ )	$\theta_u$	89	-	-		
	y axis, down ( $\phi=270^\circ$ )	$\theta_d$	89	-	-		
Gray Scale			-	-	-		7



Note : 1. Contrast Ratio(CR) is defined mathematically as :

$$\text{Contrast Ratio} = \frac{\text{Surface Luminance with all white pixels}}{\text{Surface Luminance with all black pixels}}$$

It is measured at center 1-point.

2. Surface luminance are determined after the unit has been 'ON' and 1 Hour after lighting the backlight in a dark environment at  $25 \pm 2^\circ\text{C}$ . Surface luminance is the luminance value at center 1-point across the LCD surface 50cm from the surface with all pixels displaying white. For more information see the FIG. 3.
3. The variation in surface luminance ,  $\delta$  WHITE is defined as :  
 $\delta$  WHITE(9P) = Minimum (Lon1,Lon2~ Lon8, Lon9) / Maximum (Lon1,Lon2~ Lon8, Lon9)\*100  
 Where Lon1 to Lon9 are the luminance with all pixels displaying white at 9 locations .  
 For more information, see the FIG. 3.
4. Response time is the time required for the display to transit from any gray to white (Rise Time,  $\text{Tr}_R$ ) and from any gray to black (Decay time,  $\text{Tr}_D$ ). For additional information see the FIG. 4.  
 ※ G to  $G_{BW}$  Spec stands for average value of all measured points.  
 Photo Detector : RD-80S / Field :  $2^\circ$
5. White, Red, Green, Blue Color Coordinates are measured at gray level 255(100IRE)
6. Viewing angle is the angle at which the contrast ratio is greater than 10. The angles are determined for the horizontal or x axis and the vertical or y axis with respect to the z axis which is normal to the LCD module surface. For more information, see the FIG. 5.
7. Gray scale specification  
 Gamma Value is approximately 2.2. For more information, see the Table 11.

Table 11. Gray scale specification

Gray Level	Luminance [%] (Typ)
L0	0.07(TBD)
L15	0.27
L31	1.04
L47	2.49
L63	4.68
L79	7.66
L95	11.5
L111	16.1
L127	21.6
L143	28.1
L159	35.4
L175	43.7
L191	53.0
L207	63.2
L223	74.5
L239	86.7
L255	100

Measuring point for surface luminance & measuring point for luminance variation.

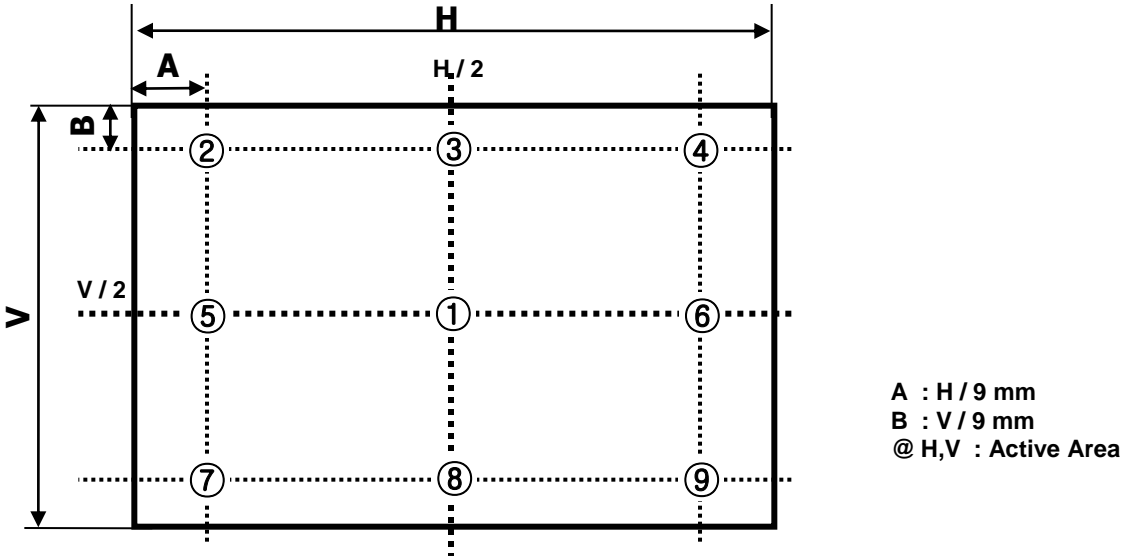

FIG. 3 9 Points for Luminance Measure

Response time is defined as the following figure and shall be measured by switching the input signal for “Gray(N)” and “Black or White”.

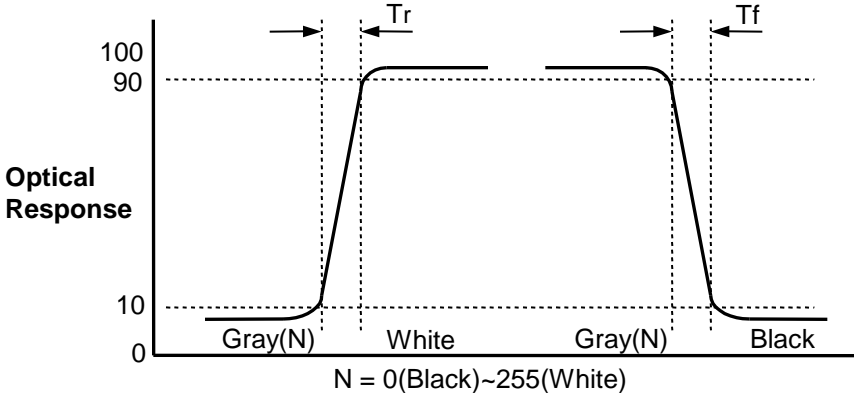

FIG. 4 Response Time

Dimension of viewing angle range

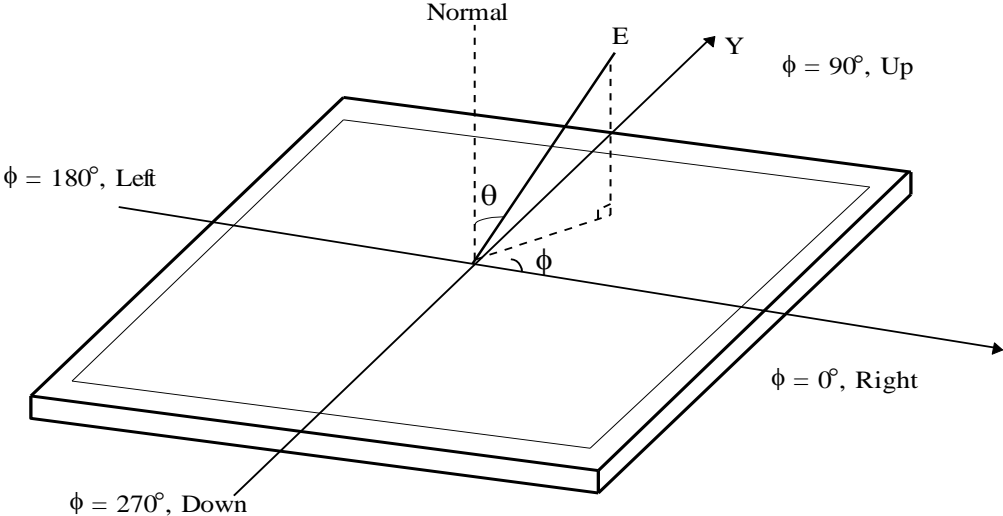

FIG. 5 Viewing Angle

## 5. Mechanical Characteristics

Table 12 provides general mechanical characteristics.

**Table 12. MECHANICAL CHARACTERISTICS**

Item	Value	
Outline Dimension	Horizontal	731.9 mm
	Vertical	431.4mm
	Depth	58 mm
Bezel Area	Horizontal	702.4mm
	Vertical	396.9mm
Active Display Area	Horizontal	698.4mm
	Vertical	392.85mm
Case Top	Material	SUS Like PCM
	Case Top Color	SHINE TITAN(HC583B)
	LG Logo Color	SILVER (Pantone-877C)
Weight	6.5kg (Typ.) 6.6kg(Max)	

Note : Please refer to a mechanic drawing in terms of tolerance at the next page.

## 6. Reliability

**Table 13. ENVIRONMENT TEST CONDITION**

No.	Test Item	Condition
1	High temperature storage test	Ta= 60°C 90% 240h
2	Low temperature storage test	Ta= -20°C 240h
3	High temperature operation test	Ta= 50°C 50%RH 500h
4	Low temperature operation test	Ta= 0°C 500h
5	Humidity condition Operation	Ta= 40 °C, 90%RH
6	Altitude operating storage / shipment	0 – 16,400 ft 0 - 40,000 ft
7	Vibration test (non-operating)	TBD
8	Shock test (non-operating)	TBD

Note : 1. Before and after Reliability test, LCM should be operated with normal function.

## 7. International Standards

### 7-1. Safety

- a) UL 60065, Underwriters Laboratories Inc.  
Audio, Video and Similar Electronic Apparatus - Safety Requirements.
- b) CAN/CSA C22.2 No.60065:03, Canadian Standards Association.  
Audio, Video and Similar Electronic Apparatus - Safety Requirements.
- c) EN 60065, European Committee for Electrotechnical Standardization (CENELEC).  
Audio, Video and Similar Electronic Apparatus - Safety Requirements.
- d) IEC 60065, The International Electrotechnical Commission (IEC).  
Audio, Video and Similar Electronic Apparatus - Safety Requirements.

### 7-2. Environment

- a) RoHS, Directive 2011/65/EU of the European Parliament and of the council of 8 June 2011

## 9. Precautions

Please pay attention to the followings when you use this TFT LCD module.

### 9-1. Mounting Precautions

- (1) You must mount a module using specified mounting holes (Details refer to the drawings).
- (2) You should consider the mounting structure so that uneven force (ex. Twisted stress, Concentrated stress) is not applied to the module. And the case on which a module is mounted should have sufficient strength so that external force is not transmitted directly to the module.
- (3) Please attach the surface transparent protective plate to the surface in order to protect the polarizer. Transparent protective plate should have sufficient strength in order to resist external force.
- (4) You should adopt radiation structure to satisfy the temperature specification.
- (5) Acetic acid type and chlorine type materials for the cover case are not desirable because the former generates corrosive gas of attacking the polarizer at high temperature and the latter causes circuit break by electro-chemical reaction.
- (6) Do not touch, push or rub the exposed polarizers with glass, tweezers or anything harder than HB pencil lead. And please do not rub with dust clothes with chemical treatment. Do not touch the surface of polarizer for bare hand or greasy cloth. (Some cosmetics are detrimental to the polarizer.)
- (7) When the surface becomes dusty, please wipe gently with absorbent cotton or other soft materials like chamois soaks with petroleum benzine. Normal-hexane is recommended for cleaning the adhesives used to attach front / rear polarizers. Do not use acetone, toluene and alcohol because they cause chemical damage to the polarizer
- (8) Wipe off saliva or water drops as soon as possible. Their long time contact with polarizer causes deformations and color fading.
- (9) Do not open the case because inside circuits do not have sufficient strength.
- (10) Touching the LED Driver might cause an electric shock and damage to LED Driver. Please always use antistatic tools when handling the LED Driver

### 9-2. Operating Precautions

- (1) Response time depends on the temperature. (In lower temperature, it becomes longer.)
- (2) Brightness depends on the temperature. (In lower temperature, it becomes lower.)  
And in lower temperature, response time (required time that brightness is stable after turned on) becomes longer
- (3) Be careful for condensation at sudden temperature change. Condensation makes damage to polarizer or electrical contacted parts. And after fading condensation, smear or spot will occur.
- (4) When fixed patterns are displayed for a long time, remnant image is likely to occur.
- (5) Module has high frequency circuits. Sufficient suppression to the electromagnetic interference shall be done by system manufacturers. Grounding and shielding methods may be important to minimize the interference.
- (6) Please do not give any mechanical and/or acoustical impact to LCM. Otherwise, LCM can't be operated its full characteristics perfectly.
- (7) A screw which is fastened up the steels should be a machine screw.  
(if not, it can cause conductive particles and deal LCM a fatal blow)
- (8) Please do not set LCD on its edge.
- (9) The conductive material and signal cables are kept away from LED driver inductor to prevent abnormal display, sound noise and temperature rising.



### 9-3. Electrostatic Discharge Control

Since a module is composed of electronic circuits, it is not strong to electrostatic discharge. Make certain that treatment persons are connected to ground through wrist band etc. And don't touch interface pin directly.

### 9-4. Precautions for Strong Light Exposure

Strong light exposure causes degradation of polarizer and color filter.

### 9-5. Storage

When storing modules as spares for a long time, the following precautions are necessary.

- (1) Store them in a dark place. Do not expose the module to sunlight or fluorescent light. Keep the temperature between 5°C and 35°C at normal humidity.
- (2) The polarizer surface should not come in contact with any other object.  
It is recommended that they be stored in the container in which they were shipped.
- (3) Storage condition is guaranteed under packing conditions.
- (4) The phase transition of Liquid Crystal in the condition of the low or high storage temperature will be recovered when the LCD module returns to the normal condition.

### 9-6. Handling Precautions for Protection Film

- (1) The protection film is attached to the bezel with a small masking tape.  
When the protection film is peeled off, static electricity is generated between the film and polarizer.  
This should be peeled off slowly and carefully by people who are electrically grounded and with well ion-blown equipment or in such a condition, etc.
- (2) When the module with protection film attached is stored for a long time, sometimes there remains a very small amount of glue still on the bezel after the protection film is peeled off.
- (3) You can remove the glue easily. When the glue remains on the bezel surface or its vestige is recognized, please wipe them off with absorbent cotton waste or other soft material like chamois soaked with normal-hexane.

### 9-7. Appropriate Condition for Commercial Display

- Generally large-sized LCD modules are designed for consumer applications (TV).  
Accordingly, a long-term display like in Commercial Display application, can cause uneven display including image sticking. To optimize module's lifetime and function, several operating usages are required.

#### 1. Normal operating condition

- Temperature: 0 ~ 40°C
  - Operating Ambient Humidity : 10 ~ 90 %
  - Display pattern: dynamic pattern (Real display)
- Note) Long-term static display can cause image sticking.

#### 2. Operating usages under abnormal condition

##### a. Ambient condition

- Well-ventilated place is recommended to set up Commercial Display system.

##### b. Power and screen save

- Periodical power-off or screen save is needed after long-term display.

# APPENDIX- III-1

■ Required signal assignment for Flat Link (Thine : THC63LVD103) Transmitter(Pin7= “L” or “NC”)

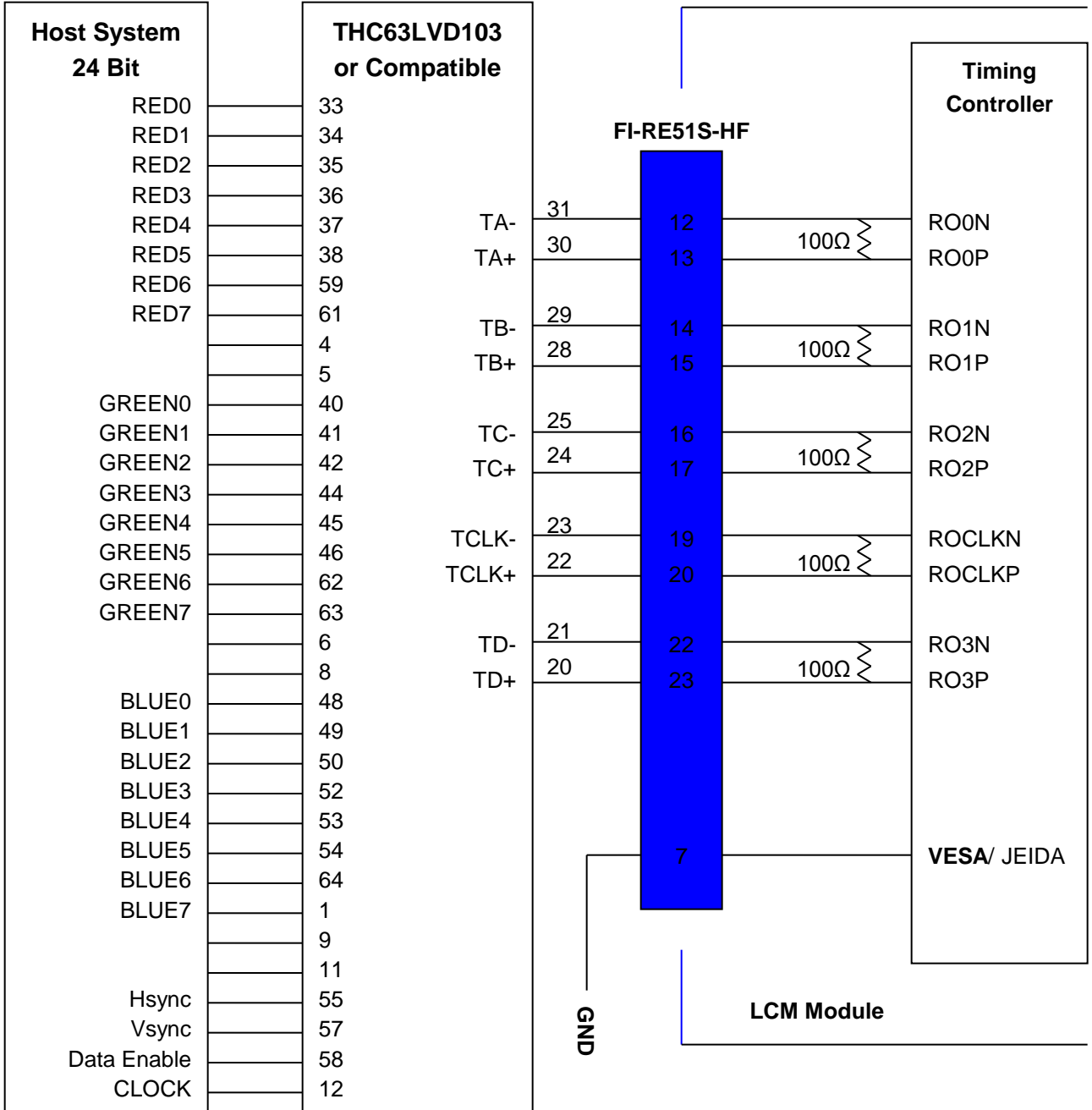

- Note: 1. The LCD module uses a 100 Ohm[Ω] resistor between positive and negative lines of each receiver input.  
 2. Refer to LVDS Transmitter Data Sheet for detail descriptions. (THC63LVD103 or Compatible)  
 3. '7' means MSB and '0' means LSB at R,G,B pixel data.

# APPENDIX- III-2

■ Required signal assignment for Flat Link (Thine : THC63LVD103) Transmitter(Pin7= "H" )

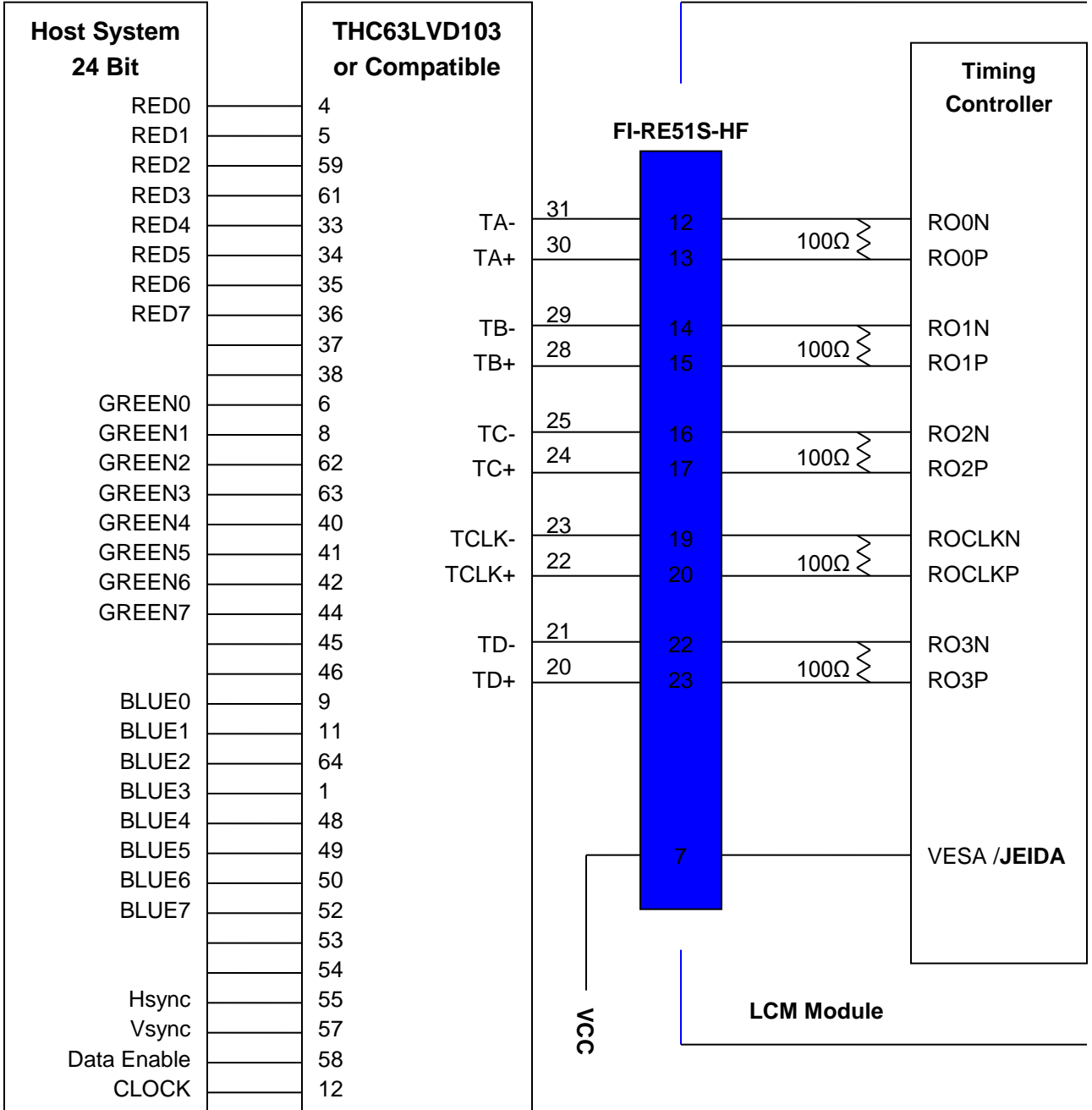

- Note :1. The LCD module uses a 100 Ohm[Ω] resistor between positive and negative lines of each receiver input.  
 2. Refer to LVDS Transmitter Data Sheet for detail descriptions. (THC63LVD103 or Compatible)  
 3. '7' means MSB and '0' means LSB at R,G,B pixel data.

# APPENDIX- IV

■ LVDS Data-Mapping Information (8 Bit )

1) LVDS Select : "H" Data-Mapping (JEIDA format)

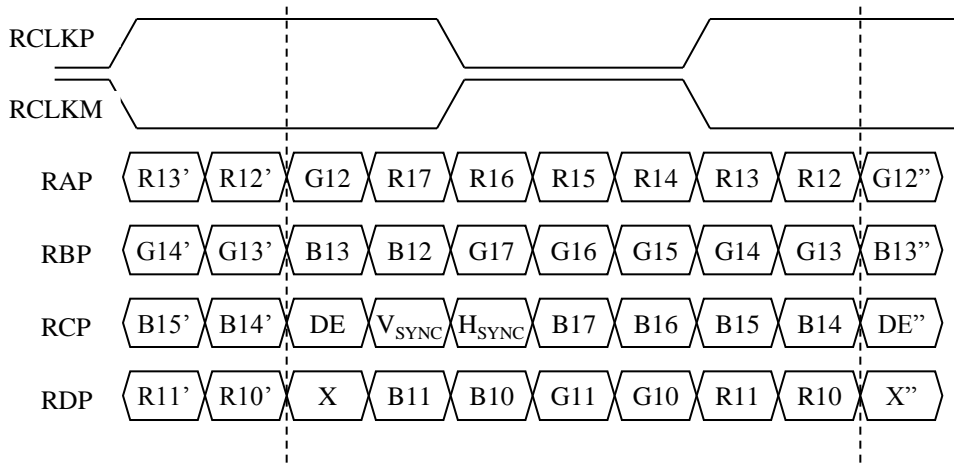

2) LVDS Select : "L" Data-Mapping (VESA format)

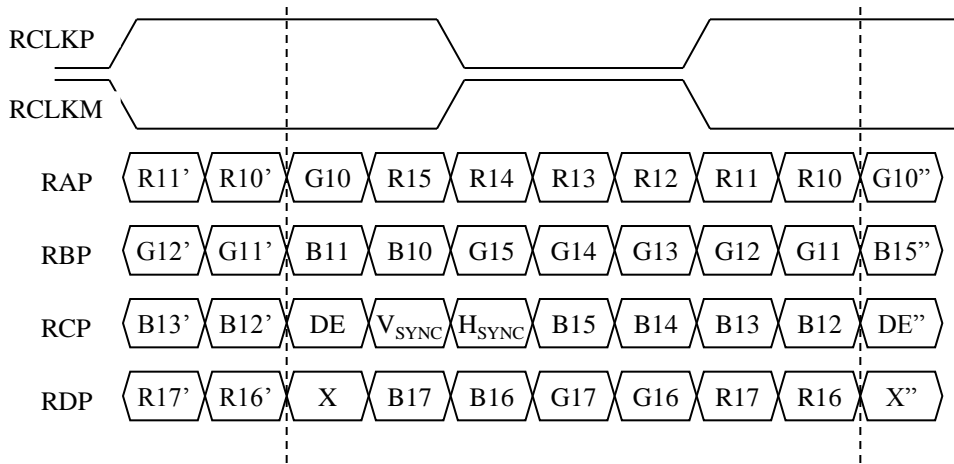

# APPENDIX- V

■ Option Pin Circuit Block Diagram

1) Circuit Block Diagram of LVDS Format Selection pin

